

Bisagras • elongated on both sides

EH 25165.



Descripción del Producto

The different versions cover many applications that require a low load.

These metal hinges are characterised by their simple design and the different versions:

- without bores
- with bores
- with bores for countersunk screws

The version without bores can be assembled by welding or by inserting a specific drilling pattern.

Material

Cuerpo

- Acero inoxidable 1.4301
- Acero, cincado por galvanización, pasivado

Eje

- Acero inoxidable 1.4301

Dibujo

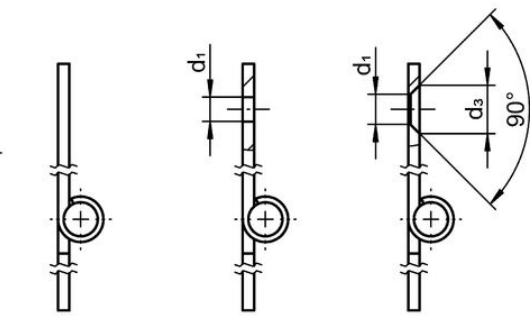
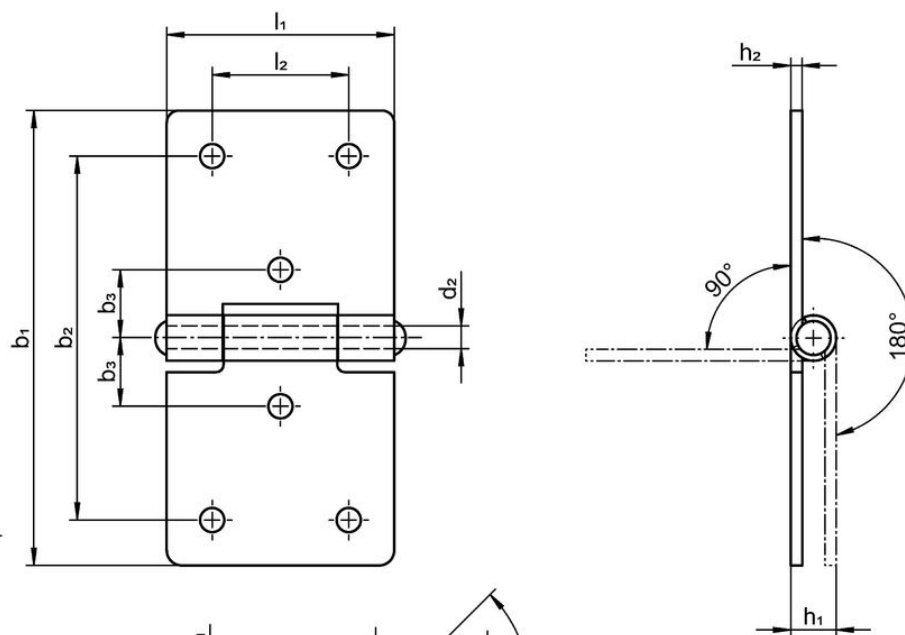

picture 1

picture 2

picture 3

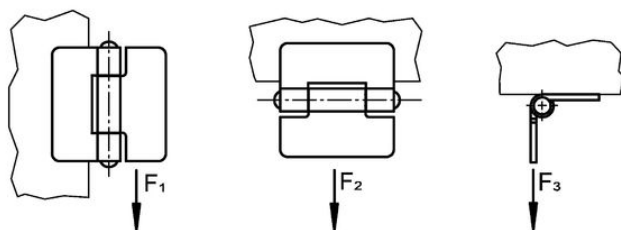

Información para el pedido

Dimensiones										Fuerza de sujeción			[g]	Referencia
b ₁	l ₁	b ₂	b ₃	d ₁	d ₂	d ₃	h ₁	h ₂	l ₂	F ₁	F ₂	F ₃		
[mm]										[N]				
without bores – croquis 1, Acero inoxidable														
60	30	–	–	–	3	–	6	1,5	–	700	500	450	25	25165.0050
80	40	–	–	–	4	–	8	2,0	–	1200	1000	1000	59	25165.0075
100	50	–	–	–	6	–	10	2,0	–	1200	1600	700	99	25165.0005
120	60	–	–	–	6	–	10	2,0	–	1100	2500	1000	139	25165.0010
with bores – croquis 2, Acero inoxidable														
60	30	48	9,0	3,2	3	–	6	1,5	18	700	500	450	24	25165.0150
80	40	65	12,5	4,2	4	–	8	2,0	25	1200	1000	1000	58	25165.0175
100	50	80	15,0	5,2	6	–	10	2,0	30	1200	1600	700	98	25165.0105
120	60	96	18,0	5,2	6	–	10	2,0	36	1100	2500	1000	136	25165.0110
with bores – croquis 2, Acero														
60	30	48	9,0	3,2	3	–	6	1,5	18	700	500	450	24	25165.1050
80	40	65	12,5	4,2	4	–	8	2,0	25	1200	1000	1000	58	25165.1075
100	50	80	15,0	5,2	6	–	10	2,0	30	1200	1600	700	98	25165.1005
120	60	96	18,0	5,2	6	–	10	2,0	36	1100	2500	1000	136	25165.1010
with bores for countersunk screws – croquis 3, Acero inoxidable														
60	30	48	9,0	4,0	3	6,4	6	1,5	18	700	500	450	24	25165.0250
80	40	65	12,5	5,0	4	8,3	8	2,0	25	1200	1000	1000	58	25165.0275
100	50	80	15,0	5,0	6	8,3	10	2,0	30	1200	1600	700	98	25165.0205
120	60	96	18,0	5,0	6	8,3	10	2,0	36	1100	2500	1000	136	25165.0210
with bores for countersunk screws – croquis 3, Acero														
60	30	48	9,0	4,0	3	6,4	6	1,5	18	700	500	450	24	25165.2050
80	40	65	12,5	5,0	4	8,3	8	2,0	25	1200	1000	1000	58	25165.2075
100	50	80	15,0	5,0	6	8,3	10	2,0	30	1200	1600	700	98	25165.2005
120	60	96	18,0	5,0	6	8,3	10	2,0	36	1100	2500	1000	136	25165.2010

Cumplimiento

Cumple con RoHS

Cumple con la Directiva 2011/65/UE y la Directiva 2015/863.

No contiene sustancias SVHC

Ninguna sustancia SVHC con más del 0,1% p/p contenida - Lista SVHC [REACH] desde 23.01.2024.

No contiene sustancias de la Proposición 65

No se incluyen sustancias de la Propuesta 65.

<https://www.P65Warnings.ca.gov/>

Libre de Materiales Conflictivos

Este producto no contiene ninguna sustancia designada como "minerales en conflicto" como tantalio, estaño, oro o tungsteno de la República Democrática del Congo o países adyacentes.