

Čepy s kuličkami • jednočinné - dle NAS / MS17986 EH 4212.



Popis produktu

Čepy s kuličkami dle MS17986 / NAS1333-1343 se používají k rychlé fixaci, aretaci, přestavení, výměně a zajištění. Rychlá a snadná možnost uvolnění pro často opakovaná spojení. Čepy s kuličkami (Quick Release Pins) jsou vyrobeny podle letecké normy MS / NAS a testovány podle NAS 1332.

Povrchová úprava:

- Všechny díly z nerez jsou pasivované podle AMS2700
- Všechny díly z eloxovaného hliníku podle MIL-A-8625

Tepelná úprava:

- Pouzdro: Rc. 40 min. (AMS2759, podmínka H900)
- Šroub: Rc. 40 min. (AMS2759, podmínka H900)
- Koule: Rc. 58-62 min. (AMS2759)

Materiál

Pouzdro

- Nerez, tvrzená, pasivovaná - CRES 17-4PH (specifikace AMS5643)

Šroub

- Nerez, tvrzená, pasivovaná - CRES 17-4PH (specifikace AMS5643)

Pružina

- Nerez, pasivovaná - CRES 302 (specifikace ASTM-A-313)

Držadlo

- Hliník, černá, elox - Slitina hliníku 380 (specifikace ASTM B85/B85)

Upevňovací kroužek

- Nerez, pasivovaná - CRES 302 (specifikace ASTM A-313/A313M)

Tlačítko

- Nerez, pasivovaná - CRES 303 (specifikace ASTM A484/484M)

Kulička

- Nerez, tvrzená, pasivovaná - CRES 440C (specifikace AMS5630)

Obsluha

Čepy s kuličkami, jednočinné samosvorné. Stisknutím tlačítka se kuličky odblokuje.

Další informace

Poznámky

Všechny další rozměry jsou k dispozici na vyžádání.

Jiné kombinace rozměrů a délek, které zde nejsou uvedeny a které odpovídají normě, lze vyrobit na přání zákazníka.



Nestandardní provedení dle poptávky.

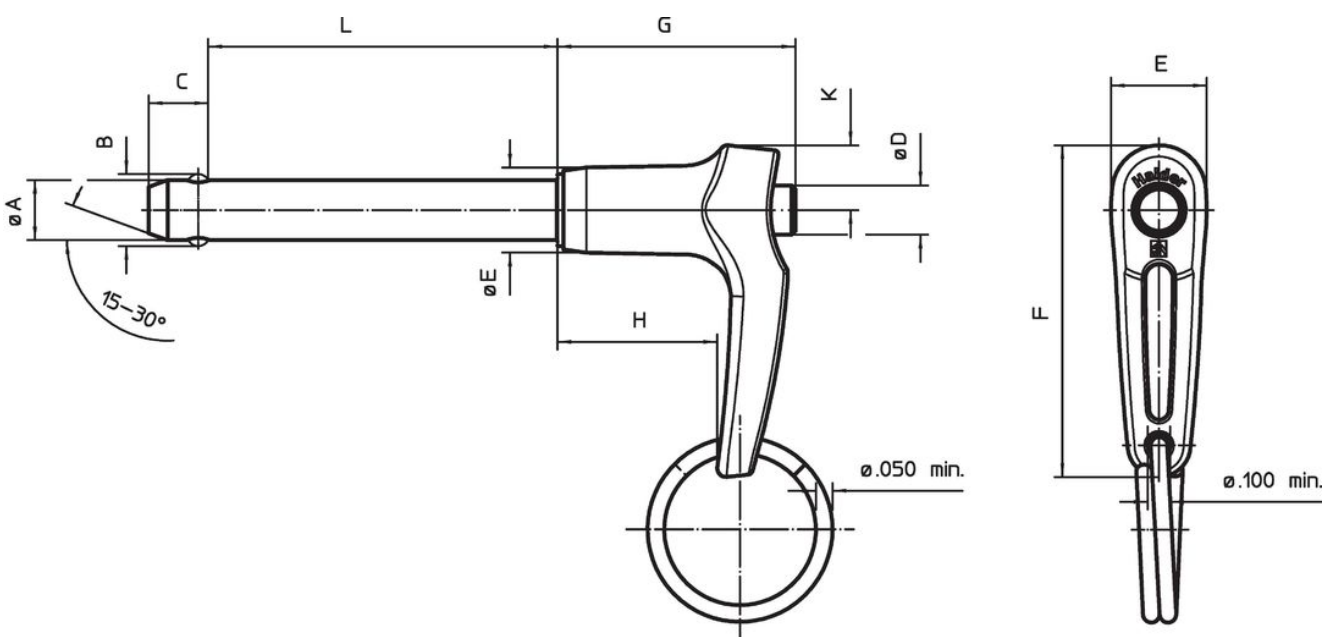

- Tento produkt je vyroben v palcových mírách.



Výkres s rozměry







Informace pro objednání

Jmenovitý průměr A	A min.	A max.	Upínací délka L +0,02 0	Rozměry									Montážní otvor max.	Pevnost ve stříhu, ve dvou průřezích min.				Standardní popis	Obj. č.
				B ±0,005	C 0 -0,04	D max.	E max.	F max.	G max.	H min.	K max.	min.			max.	[palec]			
[palec]	[palec]	[palec]	[palec]	[palec]									[palec]						
3/16	0,1870	0,1885	0,4	0,220	0,260	0,310	0,500	1,80	1,27	0,76	0,34	0,1940	5.150	-65	200	18,6	MS17986C304 / NAS1333A5C04D	4212.A04	
3/16	0,1870	0,1885	0,5	0,220	0,260	0,310	0,500	1,80	1,27	0,76	0,34	0,1940	5.150	-65	200	18,9	MS17986C305 / NAS1333A5C05D	4212.A05	
3/16	0,1870	0,1885	0,6	0,220	0,260	0,310	0,500	1,80	1,27	0,76	0,34	0,1940	5.150	-65	200	19,2	MS17986C306 / NAS1333A5C06D	4212.A06	
3/16	0,1870	0,1885	0,8	0,220	0,260	0,310	0,500	1,80	1,27	0,76	0,34	0,1940	5.150	-65	200	19,9	MS17986C308 / NAS1333A5C08D	4212.A08	
3/16	0,1870	0,1885	1,0	0,220	0,260	0,310	0,500	1,80	1,27	0,76	0,34	0,1940	5.150	-65	200	20,6	MS17986C310 / NAS1333A5C10D	4212.A10	
3/16	0,1870	0,1885	1,3	0,220	0,260	0,310	0,500	1,80	1,27	0,76	0,34	0,1940	5.150	-65	200	21,6	MS17986C313 / NAS1333A5C13D	4212.A13	
3/16	0,1870	0,1885	1,4	0,220	0,260	0,310	0,500	1,80	1,27	0,76	0,34	0,1940	5.150	-65	200	22,0	MS17986C314 / NAS1333A5C14D	4212.A14	
3/16	0,1870	0,1885	1,6	0,220	0,260	0,310	0,500	1,80	1,27	0,76	0,34	0,1940	5.150	-65	200	22,6	MS17986C316 / NAS1333A5C16D	4212.A16	
3/16	0,1870	0,1885	1,7	0,220	0,260	0,310	0,500	1,80	1,27	0,76	0,34	0,1940	5.150	-65	200	23,0	MS17986C317 / NAS1333A5C17D	4212.A17	
3/16	0,1870	0,1885	1,8	0,220	0,260	0,310	0,500	1,80	1,27	0,76	0,34	0,1940	5.150	-65	200	23,3	MS17986C318 / NAS1333A5C18D	4212.A18	
3/16	0,1870	0,1885	2,0	0,220	0,260	0,310	0,500	1,80	1,27	0,76	0,34	0,1940	5.150	-65	200	24,0	MS17986C320 / NAS1333A5C20D	4212.A20	
3/16	0,1870	0,1885	2,2	0,220	0,260	0,310	0,500	1,80	1,27	0,76	0,34	0,1940	5.150	-65	200	24,7	MS17986C322 / NAS1333A5C22D	4212.A22	
3/16	0,1870	0,1885	2,3	0,220	0,260	0,310	0,500	1,80	1,27	0,76	0,34	0,1940	5.150	-65	200	25,0	MS17986C323 / NAS1333A5C23D	4212.A23	
1/4	0,2470	0,2485	0,4	0,289	0,290	0,310	0,500	1,80	1,27	0,76	0,34	0,2540	9.200	-65	200	20,6	MS17986C404 / NAS1334A5C04D	4212.B04	
1/4	0,2470	0,2485	0,5	0,289	0,290	0,310	0,500	1,80	1,27	0,76	0,34	0,2540	9.200	-65	200	21,2	MS17986C405 / NAS1334A5C05D	4212.B05	
1/4	0,2470	0,2485	0,6	0,289	0,290	0,310	0,500	1,80	1,27	0,76	0,34	0,2540	9.200	-65	200	21,8	MS17986C406 / NAS1334A5C06D	4212.B06	
1/4	0,2470	0,2485	0,7	0,289	0,290	0,310	0,500	1,80	1,27	0,76	0,34	0,2540	9.200	-65	200	22,5	MS17986C407 / NAS1334A5C07D	4212.B07	
1/4	0,2470	0,2485	0,8	0,289	0,290	0,310	0,500	1,80	1,27	0,76	0,34	0,2540	9.200	-65	200	23,1	MS17986C408 / NAS1334A5C08D	4212.B08	
1/4	0,2470	0,2485	1,0	0,289	0,290	0,310	0,500	1,80	1,27	0,76	0,34	0,2540	9.200	-65	200	24,3	MS17986C410 / NAS1334A5C10D	4212.B10	
1/4	0,2470	0,2485	1,1	0,289	0,290	0,310	0,500	1,80	1,27	0,76	0,34	0,2540	9.200	-65	200	24,8	MS17986C411 / NAS1334A5C11D	4212.B11	
1/4	0,2470	0,2485	1,2	0,289	0,290	0,310	0,500	1,80	1,27	0,76	0,34	0,2540	9.200	-65	200	25,6	MS17986C412 / NAS1334A5C12D	4212.B12	
1/4	0,2470	0,2485	1,3	0,289	0,290	0,310	0,500	1,80	1,27	0,76	0,34	0,2540	9.200	-65	200	26,2	MS17986C413 / NAS1334A5C13D	4212.B13	
1/4	0,2470	0,2485	1,4	0,289	0,290	0,310	0,500	1,80	1,27	0,76	0,34	0,2540	9.200	-65	200	26,8	MS17986C414 / NAS1334A5C14D	4212.B14	
1/4	0,2470	0,2485	1,5	0,289	0,290	0,310	0,500	1,80	1,27	0,76	0,34	0,2540	9.200	-65	200	27,4	MS17986C415 / NAS1334A5C15D	4212.B15	
1/4	0,2470	0,2485	1,6	0,289	0,290	0,310	0,500	1,80	1,27	0,76	0,34	0,2540	9.200	-65	200	28,0	MS17986C416 / NAS1334A5C16D	4212.B16	
1/4	0,2470	0,2485	1,7	0,289	0,290	0,310	0,500	1,80	1,27	0,76	0,34	0,2540	9.200	-65	200	28,6	MS17986C417 / NAS1334A5C17D	4212.B17	
1/4	0,2470	0,2485	1,8	0,289	0,290	0,310	0,500	1,80	1,27	0,76	0,34	0,2540	9.200	-65	200	29,2	MS17986C418 / NAS1334A5C18D	4212.B18	
1/4	0,2470	0,2485	1,9	0,289	0,290	0,310	0,500	1,80	1,27	0,76	0,34	0,2540	9.200	-65	200	29,8	MS17986C419 / NAS1334A5C19D	4212.B19	
1/4	0,2470	0,2485	2,0	0,289	0,290	0,310	0,500	1,80	1,27	0,76	0,34	0,2540	9.200	-65	200	30,4	MS17986C420 / NAS1334A5C20D	4212.B20	
1/4	0,2470	0,2485	2,1	0,289	0,290	0,310	0,500	1,80	1,27	0,76	0,34	0,2540	9.200	-65	200	31,1	MS17986C421 / NAS1334A5C21D	4212.B21	

Jmenovitý průměr A	A min.	A max.	Upínací délka L +0,02 0	Rozměry								Montážní otvor max.	Pevnost ve stříhu, ve dvou průřezích min.				Standardní popis	Obj. č.
				B ±0,005	C 0 -0,04	D max.	E max.	F max.	G max.	H min.	K max.			min.	max.			
[palec]	[palec]	[palec]	[palec]	[palec]								[palec]						
1/4	0,2470	0,2485	2,2	0,289	0,290	0,310	0,500	1,80	1,27	0,76	0,34	0,2540	9.200	-65	200	31,7	MS17986C422 / NAS1334A5C22D	4212.B22
1/4	0,2470	0,2485	2,4	0,289	0,290	0,310	0,500	1,80	1,27	0,76	0,34	0,2540	9.200	-65	200	32,9	MS17986C424 / NAS1334A5C24D	4212.B24
1/4	0,2470	0,2485	2,5	0,289	0,290	0,310	0,500	1,80	1,27	0,76	0,34	0,2540	9.200	-65	200	33,5	MS17986C425 / NAS1334A5C25D	4212.B25
1/4	0,2470	0,2485	2,6	0,289	0,290	0,310	0,500	1,80	1,27	0,76	0,34	0,2540	9.200	-65	200	34,2	MS17986C426 / NAS1334A5C26D	4212.B26
1/4	0,2470	0,2485	2,8	0,289	0,290	0,310	0,500	1,80	1,27	0,76	0,34	0,2540	9.200	-65	200	35,4	MS17986C428 / NAS1334A5C28D	4212.B28
1/4	0,2470	0,2485	3,0	0,289	0,290	0,310	0,500	1,80	1,27	0,76	0,34	0,2540	9.200	-65	200	36,6	MS17986C430 / NAS1334A5C30D	4212.B30
1/4	0,2470	0,2485	3,1	0,289	0,290	0,310	0,500	1,80	1,27	0,76	0,34	0,2540	9.200	-65	200	37,2	MS17986C431 / NAS1334A5C31D	4212.B31
1/4	0,2470	0,2485	3,4	0,289	0,290	0,310	0,500	1,80	1,27	0,76	0,34	0,2540	9.200	-65	200	39,0	MS17986C434 / NAS1334A5C34D	4212.B34
1/4	0,2470	0,2485	3,6	0,289	0,290	0,310	0,500	1,80	1,27	0,76	0,34	0,2540	9.200	-65	200	40,3	MS17986C436 / NAS1334A5C36D	4212.B36
1/4	0,2470	0,2485	4,5	0,289	0,290	0,310	0,500	1,80	1,27	0,76	0,34	0,2540	9.200	-65	200	45,8	MS17986C445 / NAS1334A5C45D	4212.B45
1/4	0,2470	0,2485	5,2	0,289	0,290	0,310	0,500	1,80	1,27	0,76	0,34	0,2540	9.200	-65	200	50,1	MS17986C452 / NAS1334A5C52D	4212.B52
1/4	0,2470	0,2485	6,0	0,289	0,290	0,310	0,500	1,80	1,27	0,76	0,34	0,2540	9.200	-65	200	55,0	MS17986C460 / NAS1334A5C60D	4212.B60
5/16	0,3095	0,3110	0,4	0,375	0,330	0,310	0,500	1,80	1,27	0,76	0,34	0,3165	14.400	-65	200	23,8	MS17986C504 / NAS1335A5C04D	4212.C04
5/16	0,3095	0,3110	0,5	0,375	0,330	0,310	0,500	1,80	1,27	0,76	0,34	0,3165	14.400	-65	200	24,8	MS17986C505 / NAS1335A5C05D	4212.C05
5/16	0,3095	0,3110	0,6	0,375	0,330	0,310	0,500	1,80	1,27	0,76	0,34	0,3165	14.400	-65	200	25,7	MS17986C506 / NAS1335A5C06D	4212.C06
5/16	0,3095	0,3110	0,7	0,375	0,330	0,310	0,500	1,80	1,27	0,76	0,34	0,3165	14.400	-65	200	26,7	MS17986C507 / NAS1335A5C07D	4212.C07
5/16	0,3095	0,3110	0,8	0,375	0,330	0,310	0,500	1,80	1,27	0,76	0,34	0,3165	14.400	-65	200	27,6	MS17986C508 / NAS1335A5C08D	4212.C08
5/16	0,3095	0,3110	1,0	0,375	0,330	0,310	0,500	1,80	1,27	0,76	0,34	0,3165	14.400	-65	200	29,5	MS17986C510 / NAS1335A5C10D	4212.C10
5/16	0,3095	0,3110	1,1	0,375	0,330	0,310	0,500	1,80	1,27	0,76	0,34	0,3165	14.400	-65	200	30,4	MS17986C511 / NAS1335A5C11D	4212.C11
5/16	0,3095	0,3110	1,2	0,375	0,330	0,310	0,500	1,80	1,27	0,76	0,34	0,3165	14.400	-65	200	31,4	MS17986C512 / NAS1335A5C12D	4212.C12
5/16	0,3095	0,3110	1,3	0,375	0,330	0,310	0,500	1,80	1,27	0,76	0,34	0,3165	14.400	-65	200	32,3	MS17986C513 / NAS1335A5C13D	4212.C13
5/16	0,3095	0,3110	1,4	0,375	0,330	0,310	0,500	1,80	1,27	0,76	0,34	0,3165	14.400	-65	200	33,3	MS17986C514 / NAS1335A5C14D	4212.C14
5/16	0,3095	0,3110	1,5	0,375	0,330	0,310	0,500	1,80	1,27	0,76	0,34	0,3165	14.400	-65	200	34,2	MS17986C515 / NAS1335A5C15D	4212.C15
5/16	0,3095	0,3110	1,6	0,375	0,330	0,310	0,500	1,80	1,27	0,76	0,34	0,3165	14.400	-65	200	35,2	MS17986C516 / NAS1335A5C16D	4212.C16
5/16	0,3095	0,3110	1,7	0,375	0,330	0,310	0,500	1,80	1,27	0,76	0,34	0,3165	14.400	-65	200	36,1	MS17986C517 / NAS1335A5C17D	4212.C17
5/16	0,3095	0,3110	1,8	0,375	0,330	0,310	0,500	1,80	1,27	0,76	0,34	0,3165	14.400	-65	200	37,1	MS17986C518 / NAS1335A5C18D	4212.C18
5/16	0,3095	0,3110	2,0	0,375	0,330	0,310	0,500	1,80	1,27	0,76	0,34	0,3165	14.400	-65	200	39,0	MS17986C520 / NAS1335A5C20D	4212.C20
5/16	0,3095	0,3110	2,3	0,375	0,330	0,310	0,500	1,80	1,27	0,76	0,34	0,3165	14.400	-65	200	41,8	MS17986C523 / NAS1335A5C23D	4212.C23
5/16	0,3095	0,3110	2,4	0,375	0,330	0,310	0,500	1,80	1,27	0,76	0,34	0,3165	14.400	-65	200	42,8	MS17986C524 / NAS1335A5C24D	4212.C24
5/16	0,3095	0,3110	2,5	0,375	0,330	0,310	0,500	1,80	1,27	0,76	0,34	0,3165	14.400	-65	200	43,7	MS17986C525 / NAS1335A5C25D	4212.C25
5/16	0,3095	0,3110	2,8	0,375	0,330	0,310	0,500	1,80	1,27	0,76	0,34	0,3165	14.400	-65	200	46,5	MS17986C528 / NAS1335A5C28D	4212.C28
5/16	0,3095	0,3110	2,9	0,375	0,330	0,310	0,500	1,80	1,27	0,76	0,34	0,3165	14.400	-65	200	47,5	MS17986C529 / NAS1335A5C29D	4212.C29

Jmenovitý průměr A	A min.	A max.	Upínací délka L +0,02 0	Rozměry								Montážní otvor max.	Pevnost ve stříhu, ve dvou průřezích min.				Standardní popis	Obj. č.
				B ±0,005	C 0 -0,04	D max.	E max.	F max.	G max.	H min.	K max.			min.	max.			
[palec]	[palec]	[palec]	[palec]	[palec]								[palec]						
5/16	0,3095	0,3110	3,0	0,375	0,330	0,310	0,500	1,80	1,27	0,76	0,34	0,3165	14.400	-65	200	48,4	MS17986C530 / NAS1335A5C30D	4212.C30
5/16	0,3095	0,3110	3,3	0,375	0,330	0,310	0,500	1,80	1,27	0,76	0,34	0,3165	14.400	-65	200	51,3	MS17986C533 / NAS1335A5C33D	4212.C33
5/16	0,3095	0,3110	3,4	0,375	0,330	0,310	0,500	1,80	1,27	0,76	0,34	0,3165	14.400	-65	200	52,2	MS17986C534 / NAS1335A5C34D	4212.C34
5/16	0,3095	0,3110	3,6	0,375	0,330	0,310	0,500	1,80	1,27	0,76	0,34	0,3165	14.400	-65	200	54,1	MS17986C536 / NAS1335A5C36D	4212.C36
5/16	0,3095	0,3110	3,8	0,375	0,330	0,310	0,500	1,80	1,27	0,76	0,34	0,3165	14.400	-65	200	56,0	MS17986C538 / NAS1335A5C38D	4212.C38
5/16	0,3095	0,3110	4,0	0,375	0,330	0,310	0,500	1,80	1,27	0,76	0,34	0,3165	14.400	-65	200	64,0	MS17986C540 / NAS1335A5C40D	4212.C40
3/8	0,3720	0,3735	0,5	0,440	0,365	0,390	0,625	2,03	1,45	0,85	0,39	0,3790	20.700	-65	200	38,4	MS17986C605 / NAS1336A5C05D	4212.D05
3/8	0,3720	0,3735	0,8	0,440	0,365	0,390	0,625	2,03	1,45	0,85	0,39	0,3790	20.700	-65	200	42,5	MS17986C608 / NAS1336A5C08D	4212.D08
3/8	0,3720	0,3735	1,0	0,440	0,365	0,390	0,625	2,03	1,45	0,85	0,39	0,3790	20.700	-65	200	45,2	MS17986C610 / NAS1336A5C10D	4212.D10
3/8	0,3720	0,3735	1,1	0,440	0,365	0,390	0,625	2,03	1,45	0,85	0,39	0,3790	20.700	-65	200	47,0	MS17986C611 / NAS1336A5C11D	4212.D11
3/8	0,3720	0,3735	1,2	0,440	0,365	0,390	0,625	2,03	1,45	0,85	0,39	0,3790	20.700	-65	200	47,0	MS17986C612 / NAS1336A5C12D	4212.D12
3/8	0,3720	0,3735	1,3	0,440	0,365	0,390	0,625	2,03	1,45	0,85	0,39	0,3790	20.700	-65	200	49,3	MS17986C613 / NAS1336A5C13D	4212.D13
3/8	0,3720	0,3735	1,4	0,440	0,365	0,390	0,625	2,03	1,45	0,85	0,39	0,3790	20.700	-65	200	50,7	MS17986C614 / NAS1336A5C14D	4212.D14
3/8	0,3720	0,3735	1,5	0,440	0,365	0,390	0,625	2,03	1,45	0,85	0,39	0,3790	20.700	-65	200	52,0	MS17986C615 / NAS1336A5C15D	4212.D15
3/8	0,3720	0,3735	1,6	0,440	0,365	0,390	0,625	2,03	1,45	0,85	0,39	0,3790	20.700	-65	200	53,4	MS17986C616 / NAS1336A5C16D	4212.D16
3/8	0,3720	0,3735	1,4	0,440	0,365	0,390	0,625	2,03	1,45	0,85	0,39	0,3790	20.700	-65	200	54,8	MS17986C617 / NAS1336A5C17D	4212.D17
3/8	0,3720	0,3735	1,8	0,440	0,365	0,390	0,625	2,03	1,45	0,85	0,39	0,3790	20.700	-65	200	56,1	MS17986C618 / NAS1336A5C18D	4212.D18
3/8	0,3720	0,3735	2,0	0,440	0,365	0,390	0,625	2,03	1,45	0,85	0,39	0,3790	20.700	-65	200	58,8	MS17986C620 / NAS1336A5C20D	4212.D20
3/8	0,3720	0,3735	2,2	0,440	0,365	0,390	0,625	2,03	1,45	0,85	0,39	0,3790	20.700	-65	200	61,6	MS17986C622 / NAS1336A5C22D	4212.D22
3/8	0,3720	0,3735	2,4	0,440	0,365	0,390	0,625	2,03	1,45	0,85	0,39	0,3790	20.700	-65	200	64,3	MS17986C624 / NAS1336A5C24D	4212.D24
3/8	0,3720	0,3735	2,5	0,440	0,365	0,390	0,625	2,03	1,45	0,85	0,39	0,3790	20.700	-65	200	65,6	MS17986C624 / NAS1336A5C25D	4212.D25
3/8	0,3720	0,3735	2,6	0,440	0,365	0,390	0,625	2,03	1,45	0,85	0,39	0,3790	20.700	-65	200	67,0	MS17986C626 / NAS1336A5C26D	4212.D26
3/8	0,3720	0,3735	3,0	0,440	0,365	0,390	0,625	2,03	1,45	0,85	0,39	0,3790	20.700	-65	200	72,4	MS17986C630 / NAS1336A5C30D	4212.D30
3/8	0,3720	0,3735	3,2	0,440	0,365	0,390	0,625	2,03	1,45	0,85	0,39	0,3790	20.700	-65	200	75,2	MS17986C632 / NAS1336A5C32D	4212.D32
3/8	0,3720	0,3735	4,0	0,440	0,365	0,390	0,625	2,03	1,45	0,85	0,39	0,3790	20.700	-65	200	86,0	MS17986C640 / NAS1336A5C40D	4212.D40
3/8	0,3720	0,3735	4,3	0,440	0,365	0,390	0,625	2,03	1,45	0,85	0,39	0,3790	20.700	-65	200	90,1	MS17986C643 / NAS1336A5C43D	4212.D43
3/8	0,3720	0,3735	4,5	0,440	0,365	0,390	0,625	2,03	1,45	0,85	0,39	0,3790	20.700	-65	200	92,8	MS17986C645 / NAS1336A5C45D	4212.D45
3/8	0,3720	0,3735	4,8	0,440	0,365	0,390	0,625	2,03	1,45	0,85	0,39	0,3790	20.700	-65	200	96,9	MS17986C648 / NAS1336A5C48D	4212.D48
3/8	0,3720	0,3735	5,0	0,440	0,365	0,390	0,625	2,03	1,45	0,85	0,39	0,3790	20.700	-65	200	99,6	MS17986C650 / NAS1336A5C50D	4212.D50
3/8	0,3720	0,3735	6,0	0,440	0,365	0,390	0,625	2,03	1,45	0,85	0,39	0,3790	20.700	-65	200	113,0	MS17986C660 / NAS1336A5C60D	4212.D60
7/16	0,4345	0,4360	1,0	0,509	0,380	0,390	0,625	2,03	1,47	0,85	0,39	0,4425	28.500	-65	200	52,1	MS17986C710 / NAS1337A5C10D	4212.E10
7/16	0,4345	0,4360	1,2	0,509	0,380	0,390	0,625	2,03	1,47	0,85	0,39	0,4425	28.500	-65	200	55,8	MS17986C712 / NAS1337A5C12D	4212.E12

Jmenovitý průměr A	A min.	A max.	Upínací délka L +0,02 0	Rozměry								Montážní otvor max.	Pevnost ve stříhu, ve dvou průřezích min.	 min. max.		 Standardní popis	Obj. č.	
	[palec]	[palec]		[palec]	[palec]	B ±0,005	C 0 -0,04	D max.	E max.	F max.	G max.			H min.	K max.			[palec]
7/16	0,4345	0,4360	1,3	0,509	0,380	0,390	0,625	2,03	1,47	0,85	0,39	0,4425	28.500	-65	200	57,7	MS17986C713 / NAS1337A5C13D	4212.E13
7/16	0,4345	0,4360	1,4	0,509	0,380	0,390	0,625	2,03	1,47	0,85	0,39	0,4425	28.500	-65	200	59,6	MS17986C714 / NAS1337A5C14D	4212.E14
7/16	0,4345	0,4360	1,5	0,509	0,380	0,390	0,625	2,03	1,47	0,85	0,39	0,4425	28.500	-65	200	61,4	MS17986C715 / NAS1337A5C15D	4212.E15
7/16	0,4345	0,4360	1,6	0,509	0,380	0,390	0,625	2,03	1,47	0,85	0,39	0,4425	28.500	-65	200	63,3	MS17986C716 / NAS1337A5C16D	4212.E16
7/16	0,4345	0,4360	2,0	0,509	0,380	0,390	0,625	2,03	1,47	0,85	0,39	0,4425	28.500	-65	200	70,7	MS17986C720 / NAS1337A5C20D	4212.E20
7/16	0,4345	0,4360	2,1	0,509	0,380	0,390	0,625	2,03	1,47	0,85	0,39	0,4425	28.500	-65	200	72,5	MS17986C721 / NAS1337A5C21D	4212.E21
7/16	0,4345	0,4360	2,5	0,509	0,380	0,390	0,625	2,03	1,47	0,85	0,39	0,4425	28.500	-65	200	80,0	MS17986C725 / NAS1337A5C25D	4212.E25
7/16	0,4345	0,4360	2,6	0,509	0,380	0,390	0,625	2,03	1,47	0,85	0,39	0,4425	28.500	-65	200	81,8	MS17986C726 / NAS1337A5C26D	4212.E26
7/16	0,4345	0,4360	2,8	0,509	0,380	0,390	0,625	2,03	1,47	0,85	0,39	0,4425	28.500	-65	200	85,6	MS17986C728 / NAS1337A5C28D	4212.E28
7/16	0,4345	0,4360	3,0	0,509	0,380	0,390	0,625	2,03	1,47	0,85	0,39	0,4425	28.500	-65	200	89,2	MS17986C730 / NAS1337A5C30D	4212.E30
7/16	0,4345	0,4360	3,2	0,509	0,380	0,390	0,625	2,03	1,47	0,85	0,39	0,4425	28.500	-65	200	93,0	MS17986C732 / NAS1337A5C32D	4212.E32
7/16	0,4345	0,4360	3,5	0,509	0,380	0,390	0,625	2,03	1,47	0,85	0,39	0,4425	28.500	-65	200	98,5	MS17986C735 / NAS1337A5C35D	4212.E35
7/16	0,4345	0,4360	4,0	0,509	0,380	0,390	0,625	2,03	1,47	0,85	0,39	0,4425	28.500	-65	200	108,0	MS17986C740 / NAS1337A5C40D	4212.E40
7/16	0,4345	0,4360	4,2	0,509	0,380	0,390	0,625	2,03	1,47	0,85	0,39	0,4425	28.500	-65	200	112,0	MS17986C742 / NAS1337A5C42D	4212.E42
7/16	0,4345	0,4360	5,5	0,509	0,380	0,390	0,625	2,03	1,47	0,85	0,39	0,4425	28.500	-65	200	136,0	MS17986C755 / NAS1337A5C55D	4212.E55
7/16	0,4345	0,4360	5,6	0,509	0,380	0,390	0,625	2,03	1,47	0,85	0,39	0,4425	28.500	-65	200	138,0	MS17986C756 / NAS1337A5C56D	4212.E56
1/2	0,4970	0,4985	0,7	0,594	0,460	0,565	0,800	2,36	1,60	0,85	0,50	0,5050	36.900	-65	200	67,8	MS17986C807 / NAS1338A5C07D	4212.F07
1/2	0,4970	0,4985	1,0	0,594	0,460	0,565	0,800	2,36	1,60	0,85	0,50	0,5050	36.900	-65	200	75,1	MS17986C810 / NAS1338A5C10D	4212.F10
1/2	0,4970	0,4985	1,2	0,594	0,460	0,565	0,800	2,36	1,60	0,85	0,50	0,5050	36.900	-65	200	80,0	MS17986C812 / NAS1338A5C12D	4212.F12
1/2	0,4970	0,4985	1,4	0,594	0,460	0,565	0,800	2,36	1,60	0,85	0,50	0,5050	36.900	-65	200	84,9	MS17986C814 / NAS1338A5C14D	4212.F14
1/2	0,4970	0,4985	1,5	0,594	0,460	0,565	0,800	2,36	1,60	0,85	0,50	0,5050	36.900	-65	200	87,2	MS17986C815 / NAS1338A5C15D	4212.F15
1/2	0,4970	0,4985	1,6	0,594	0,460	0,565	0,800	2,36	1,60	0,85	0,50	0,5050	36.900	-65	200	89,7	MS17986C816 / NAS1338A5C16D	4212.F16
1/2	0,4970	0,4985	1,7	0,594	0,460	0,565	0,800	2,36	1,60	0,85	0,50	0,5050	36.900	-65	200	92,2	MS17986C817 / NAS1338A5C17D	4212.F17
1/2	0,4970	0,4985	1,8	0,594	0,460	0,565	0,800	2,36	1,60	0,85	0,50	0,5050	36.900	-65	200	94,6	MS17986C818 / NAS1338A5C18D	4212.F18
1/2	0,4970	0,4985	1,9	0,594	0,460	0,565	0,800	2,36	1,60	0,85	0,50	0,5050	36.900	-65	200	97,0	MS17986C819 / NAS1338A5C19D	4212.F19
1/2	0,4970	0,4985	2,0	0,594	0,460	0,565	0,800	2,36	1,60	0,85	0,50	0,5050	36.900	-65	200	99,5	MS17986C820 / NAS1338A5C20D	4212.F20
1/2	0,4970	0,4985	2,1	0,594	0,460	0,565	0,800	2,36	1,60	0,85	0,50	0,5050	36.900	-65	200	102,0	MS17986C821 / NAS1338A5C21D	4212.F21
1/2	0,4970	0,4985	2,2	0,594	0,460	0,565	0,800	2,36	1,60	0,85	0,50	0,5050	36.900	-65	200	104,0	MS17986C822 / NAS1338A5C22D	4212.F22
1/2	0,4970	0,4985	2,3	0,594	0,460	0,565	0,800	2,36	1,60	0,85	0,50	0,5050	36.900	-65	200	107,0	MS17986C823 / NAS1338A5C23D	4212.F23
1/2	0,4970	0,4985	2,4	0,594	0,460	0,565	0,800	2,36	1,60	0,85	0,50	0,5050	36.900	-65	200	109,0	MS17986C824 / NAS1338A5C24D	4212.F24
1/2	0,4970	0,4985	2,5	0,594	0,460	0,565	0,800	2,36	1,60	0,85	0,50	0,5050	36.900	-65	200	112,0	MS17986C825 / NAS1338A5C25D	4212.F25
1/2	0,4970	0,4985	2,6	0,594	0,460	0,565	0,800	2,36	1,60	0,85	0,50	0,5050	36.900	-65	200	114,0	MS17986C826 / NAS1338A5C26D	4212.F26

Jmenovitý průměr A	A min.	A max.	Upínací délka L +0,02 0	Rozměry								Montážní otvor max.	Pevnost ve stříhu, ve dvou průřezích min.				Standardní popis	Obj. č.
				B ±0,005	C 0 -0,04	D max.	E max.	F max.	G max.	H min.	K max.			min.	max.			
[palec]	[palec]	[palec]	[palec]	[palec]								[palec]						
1/2	0,4970	0,4985	2,8	0,594	0,460	0,565	0,800	2,36	1,60	0,85	0,50	0,5050	36.900	-65	200	119,0	MS17986C828 / NAS1338A5C28D	4212.F28
1/2	0,4970	0,4985	2,9	0,594	0,460	0,565	0,800	2,36	1,60	0,85	0,50	0,5050	36.900	-65	200	121,0	MS17986C829 / NAS1338A5C29D	4212.F29
1/2	0,4970	0,4985	3,0	0,594	0,460	0,565	0,800	2,36	1,60	0,85	0,50	0,5050	36.900	-65	200	124,0	MS17986C830 / NAS1338A5C30D	4212.F30
1/2	0,4970	0,4985	3,1	0,594	0,460	0,565	0,800	2,36	1,60	0,85	0,50	0,5050	36.900	-65	200	126,0	MS17986C831 / NAS1338A5C31D	4212.F31
1/2	0,4970	0,4985	3,4	0,594	0,460	0,565	0,800	2,36	1,60	0,85	0,50	0,5050	36.900	-65	200	134,0	MS17986C834 / NAS1338A5C34D	4212.F34
1/2	0,4970	0,4985	3,5	0,594	0,460	0,565	0,800	2,36	1,60	0,85	0,50	0,5050	36.900	-65	200	136,0	MS17986C835 / NAS1338A5C35D	4212.F35
1/2	0,4970	0,4985	3,6	0,594	0,460	0,565	0,800	2,36	1,60	0,85	0,50	0,5050	36.900	-65	200	138,0	MS17986C836 / NAS1338A5C36D	4212.F36
1/2	0,4970	0,4985	3,7	0,594	0,460	0,565	0,800	2,36	1,60	0,85	0,50	0,5050	36.900	-65	200	141,0	MS17986C837 / NAS1338A5C37D	4212.F37
1/2	0,4970	0,4985	4,0	0,594	0,460	0,565	0,800	2,36	1,60	0,85	0,50	0,5050	36.900	-65	200	148,0	MS17986C840 / NAS1338A5C40D	4212.F40
1/2	0,4970	0,4985	4,1	0,594	0,460	0,565	0,800	2,36	1,60	0,85	0,50	0,5050	36.900	-65	200	151,0	MS17986C841 / NAS1338A5C41D	4212.F41
1/2	0,4970	0,4985	4,2	0,594	0,460	0,565	0,800	2,36	1,60	0,85	0,50	0,5050	36.900	-65	200	153,0	MS17986C842 / NAS1338A5C42D	4212.F42
1/2	0,4970	0,4985	4,3	0,594	0,460	0,565	0,800	2,36	1,60	0,85	0,50	0,5050	36.900	-65	200	156,0	MS17986C843 / NAS1338A5C43D	4212.F43
1/2	0,4970	0,4985	4,5	0,594	0,460	0,565	0,800	2,36	1,60	0,85	0,50	0,5050	36.900	-65	200	160,0	MS17986C845 / NAS1338A5C45D	4212.F45
1/2	0,4970	0,4985	4,8	0,594	0,460	0,565	0,800	2,36	1,60	0,85	0,50	0,5050	36.900	-65	200	168,0	MS17986C848 / NAS1338A5C48D	4212.F48
1/2	0,4970	0,4985	5,3	0,594	0,460	0,565	0,800	2,36	1,60	0,85	0,50	0,5050	36.900	-65	200	180,0	MS17986C853 / NAS1338A5C53D	4212.F53
1/2	0,4970	0,4985	5,5	0,594	0,460	0,565	0,800	2,36	1,60	0,85	0,50	0,5050	36.900	-65	200	185,0	MS17986C855 / NAS1338A5C55D	4212.F55
1/2	0,4970	0,4985	5,6	0,594	0,460	0,565	0,800	2,36	1,60	0,85	0,50	0,5050	36.900	-65	200	187,0	MS17986C856 / NAS1338A5C56D	4212.F56
1/2	0,4970	0,4985	6,0	0,594	0,460	0,565	0,800	2,36	1,60	0,85	0,50	0,5050	36.900	-65	200	197,0	MS17986C860 / NAS1338A5C60D	4212.F60
9/16	0,5595	0,5610	1,6	0,666	0,510	0,565	0,800	2,36	1,60	0,85	0,50	0,5675	46.700	-65	200	104,0	MS17986C916 / NAS1339A5C16D	4212.G16
9/16	0,5595	0,5610	1,7	0,666	0,510	0,565	0,800	2,36	1,60	0,85	0,50	0,5675	46.700	-65	200	107,0	MS17986C917 / NAS1339A5C17D	4212.G17
9/16	0,5595	0,5610	2,0	0,666	0,510	0,565	0,800	2,36	1,60	0,85	0,50	0,5675	46.700	-65	200	117,0	MS17986C920 / NAS1339A5C20D	4212.G20
9/16	0,5595	0,5610	2,5	0,666	0,510	0,565	0,800	2,36	1,60	0,85	0,50	0,5675	46.700	-65	200	132,0	MS17986C925 / NAS1339A5C25D	4212.G25
9/16	0,5595	0,5610	3,6	0,666	0,510	0,565	0,800	2,36	1,60	0,85	0,50	0,5675	46.700	-65	200	166,0	MS17986C936 / NAS1339A5C36D	4212.G36
9/16	0,5595	0,5610	4,0	0,666	0,510	0,565	0,800	2,36	1,60	0,85	0,50	0,5675	46.700	-65	200	179,0	MS17986C940 / NAS1339A5C40D	4212.G40
9/16	0,5595	0,5610	5,0	0,666	0,510	0,565	0,800	2,36	1,60	0,85	0,50	0,5675	46.700	-65	200	210,0	MS17986C950 / NAS1339A5C50D	4212.G50
9/16	0,5595	0,5610	5,5	0,666	0,510	0,565	0,800	2,36	1,60	0,85	0,50	0,5675	46.700	-65	200	226,0	MS17986C955 / NAS1339A5C55D	4212.G55
9/16	0,5595	0,5610	6,0	0,666	0,510	0,565	0,800	2,36	1,60	0,85	0,50	0,5675	46.700	-65	200	241,0	MS17986C960 / NAS1339A5C60D	4212.G60
5/8	0,6220	0,6235	0,9	0,750	0,580	0,580	0,970	3,07	1,70	0,97	0,60	0,6300	57.800	-65	200	127,0	MS17986C1009 / NAS1340A5C09D	4212.H09
5/8	0,6220	0,6235	1,4	0,750	0,580	0,580	0,970	3,07	1,70	0,97	0,60	0,6300	57.800	-65	200	147,0	MS17986C10114 / NAS1340A5C14D	4212.H14
5/8	0,6220	0,6235	2,0	0,750	0,580	0,580	0,970	3,07	1,70	0,97	0,60	0,6300	57.800	-65	200	170,0	MS17986C1020 / NAS1340A5C20D	4212.H20
5/8	0,6220	0,6235	4,0	0,750	0,580	0,580	0,970	3,07	1,70	0,97	0,60	0,6300	57.800	-65	200	247,0	MS17986C1040 / NAS1340A5C40D	4212.H40
3/4	0,7470	0,7485	0,9	0,887	0,670	0,700	1,000	3,07	1,72	0,98	0,60	0,7570	83.200	-65	200	159,0	MS17986C1209 / NAS1341A5C09D	4212.K09

Jmenovitý průměr A	A min.	A max.	Upínací délka L +0,02 0	Rozměry								Montážní otvor max.	Pevnost ve stříhu, ve dvou průřezích min.	🌡️		📦	Standardní popis	Obj. č.
				B ±0,005	C 0 -0,04	D max.	E max.	F max.	G max.	H min.	K max.			min.	max.			
[palec]	[palec]	[palec]	[palec]	[palec]								[palec]						
3/4	0,7470	0,7485	1,2	0,887	0,670	0,700	1,000	3,07	1,72	0,98	0,60	0,7570	83.200	-65	200	175,0	MS17986C1212 / NAS1341A5C12D	4212.K12
3/4	0,7470	0,7485	2,4	0,887	0,670	0,700	1,000	3,07	1,72	0,98	0,60	0,7570	83.200	-65	200	242,0	MS17986C1224 / NAS1341A5C24D	4212.K24
3/4	0,7470	0,7485	3,5	0,887	0,670	0,700	1,000	3,07	1,72	0,98	0,60	0,7570	83.200	-65	200	303,0	MS17986C1235 / NAS1341A5C35D	4212.K35
3/4	0,7470	0,7485	3,6	0,887	0,670	0,700	1,000	3,07	1,72	0,98	0,60	0,7570	83.200	-65	200	309,0	MS17986C1236 / NAS1341A5C36D	4212.K36
3/4	0,7470	0,7485	4,0	0,887	0,670	0,700	1,000	3,07	1,72	0,98	0,60	0,7570	83.200	-65	200	331,0	MS17986C1240 / NAS1341A5C40D	4212.K40
3/4	0,7470	0,7485	5,5	0,887	0,670	0,700	1,000	3,07	1,72	0,98	0,60	0,7570	83.200	-65	200	414,0	MS17986C1255 / NAS1341A5C55D	4212.K55
7/8	0,8720	0,8735	3,1	1,046	0,760	0,840	1,320	3,70	2,17	1,20	0,80	0,8820	112.500	-65	200	-	MS17986C1431 / NAS1342A5C31D	4212.L31
7/8	0,8720	0,8735	4,0	1,046	0,760	0,840	1,320	3,70	2,17	1,20	0,80	0,8820	112.500	-65	200	509,0	MS17986C1440 / NAS1342A5C40D	4212.L40
1	0,9970	0,9985	2,4	1,219	0,890	0,840	1,320	3,70	2,17	1,20	0,80	1,0100	147.200	-65	200	475,0	MS17986C1624 / NAS1343A5C24D	4212.M24
1	0,9970	0,9985	4,0	1,219	0,890	0,840	1,320	3,70	2,17	1,20	0,80	1,0100	147.200	-65	200	631,0	MS17986C1640 / NAS1343A5C40D	4212.M40
1	0,9970	0,9985	4,2	1,219	0,890	0,840	1,320	3,70	2,17	1,20	0,80	1,0100	147.200	-65	200	653,0	MS17986C1642 / NAS1343A5C42D	4212.M42
1	0,9970	0,9985	6,0	1,219	0,890	0,840	1,320	3,70	2,17	1,20	0,80	1,0100	147.200	-65	200	832,0	MS17986C1660 / NAS1343A5C60D	4212.M60

Shoda

Vyhovuje RoHS

V souladu se směrnicí 2011/65/EU a směrnicí 2015/863.

Neobsahuje látky SVHC

Žádné látky SVHC s obsahem vyšším než 0,1% hm. - seznam SVHC k 27.06.2024.

Neobsahuje látky Proposition 65

Neobsahuje látky Proposition 65.
<https://www.P65Warnings.ca.gov/>

Bez konfliktních minerálů

Tento produkt neobsahuje žádné látky označené jako "konfliktní minerály" jako je tantal, cín, zlato nebo wolfram z Demokratické republiky Kongo nebo sousedních zemí.