

Podpěry · rýhovaná nebo s hrotem

EH 22680.



Popis produktu

Pro obrobky s nepracovaným povrchem. Provedení s hrotem (obrázek 2) je obzvláště vhodné pro odlitky.

Materiál

Vložka

- Tvrdokov, rýhovaný
- Tvrdokov, s hrotem

Tělo

- Zušlechťená ocel, kalená, brynýrovaná
- Automatová ocel, tvrzená, brynýrovaná

Další informace

Další produkty

- Čípky

Výkres s rozměry

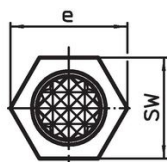
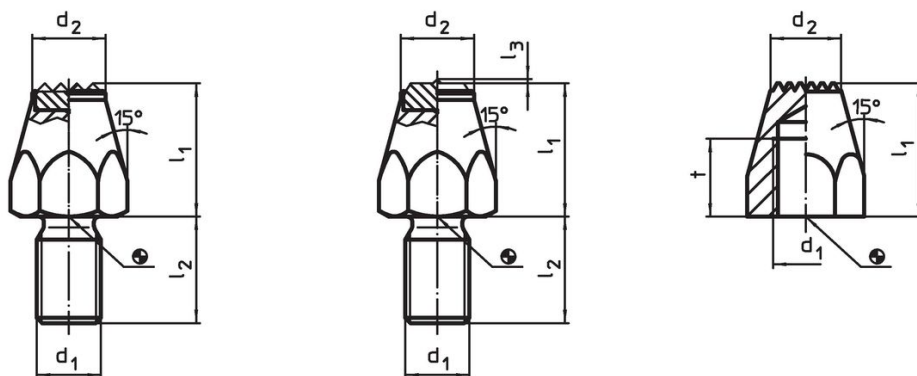

Obr. 1

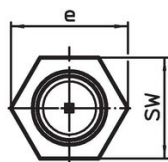

Obr. 2

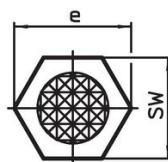

Obr. 3

Informace pro objednání

l ₁	d ₁	l ₂	Rozměry				d ₂	e	SW [mm]	Utahovací moment max. [Nm]	[g]	Obj. č.
			l ₃	t	[mm]							
s ploškou z tvrdokovu, rýhovaná, se závitovým čepem – obrázek 1												
10	M 6	11	–	–	9,5	11,5	10	7	8,8	22680.0061		
15	M 8	13	–	–	12,5	15,0	13	18	22,0	22680.0081		
20	M10	15	–	–	12,5	19,6	17	32	39,0	22680.0101		
25	M12	20	–	–	13,8	21,9	19	60	64,0	22680.0121		
s ploškou z tvrdokovu, s hrotem a závitovým čepem – obrázek 2												
10	M 6	11	0,8	–	9,5	11,5	10	7	9,1	22680.0063		
15	M 8	13	0,8	–	12,5	15,0	13	18	22,0	22680.0083		
20	M10	15	0,8	–	12,5	19,6	17	32	40,0	22680.0103		
25	M12	20	0,8	–	13,8	21,9	19	60	65,0	22680.0123		
cementovaná, rýhovaná, s vnitřním závitem – obrázek 3												
20	M 8	–	–	10	9,0	15,0	13	18	14,0	22680.0142		
25	M 8	–	–	10	9,0	15,0	13	18	20,0	22680.0144		
25	M10	–	–	13	12,5	19,6	17	32	31,0	22680.0164		
30	M10	–	–	13	12,5	19,6	17	32	40,0	22680.0166		

l ₁	d ₁	l ₂	Rozměry				SW	Utahovací moment max.	 [g]	Obj. č.
			l ₃	t	d ₂	e				
40	M10	–	–	13	12,5	19,6	17	32	60,0	22680.0168
25	M12	–	–	15	13,0	21,9	19	60	33,0	22680.0184
30	M12	–	–	15	13,0	21,9	19	60	44,0	22680.0186
40	M12	–	–	15	13,0	21,9	19	60	69,0	22680.0188

Příklad použití

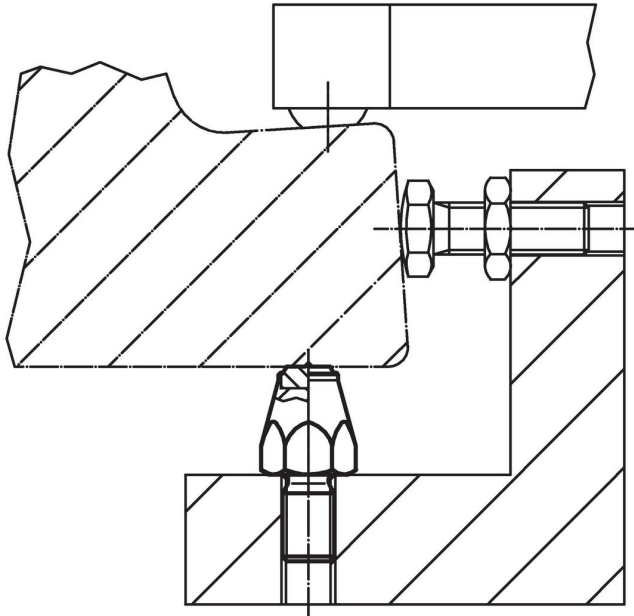

Shoda

Pro podrobné informace o shodě vyberte, prosím, požadované číslo výrobku.