

## 简短操作指南

### ！危险！

注意：使用前，请阅读原始制造商的说明。这些可以从 [www.halder.com/downloadcenter](http://www.halder.com/downloadcenter) (1) 下载。

螺纹定位扣件被设计用在提升和维持负载（不能使用在人！！）。

螺纹定位扣件不适合用于负载旋转。

脏物（例如，沙砾和碎屑，油和乳胶沉积物，灰尘……）可能会影响螺纹定位扣件的功能。

使用损坏的螺纹定位扣件会有危险。使用前，请仔细检查螺纹定位扣件（例如：变形，断裂，撕裂，损坏，螺纹组件遗失，腐蚀，解锁功能）。

必须将带螺纹的起重重完全旋入螺纹，该螺纹可以真正测量并完全支撑在轴承表面上。当插入螺纹定位扣件时，必须防止负载旋转。如果不使用螺纹吊销，请避免直接撞击它们。

损坏的螺纹定位扣件必须立即停用并维修。

禁止：

- 用颜色（尤其是红色）标记螺纹吊销
- 在超过 16,000 次负载循环后使用螺纹吊销

螺纹吊销的操作和作业只能由合格或受过指导的人员进行。只有在阅读原始制造商的说明后，才能使用和维修带螺纹的起重销。

操作和荷重

要松开螺纹组件，请按按钮（A）。要锁定螺纹组件，请松开按钮（A）。带螺纹的提升销必须完全旋入。

注意：按钮（A）藉由弹簧阻力弹回到初始位置后被锁定。

请不要对按钮长时间按着不放。

荷重  $F_1 / F_2 / F_3$ （请参阅第2页）仅适用于带有钢制保持器的提升应用。

保养：

合格的人员必须每年至少一次停止使用螺纹定位扣件，以进行正确的检查。

肉眼检查：

沙粒和研磨，断裂，撕裂，螺纹组件遗失和损坏，腐蚀，钩环处的螺钉结合损坏。

性能检查：

- 螺纹组件必须利用弹力自动锁定
- 必须确保卸扣完全运动



(1) Original operating instructions

## Short Instruction Manual

### !DANGER!

**Attention:** Read the original operating instructions before use. These can be downloaded from [www.halder.com/downloadcenter](http://www.halder.com/downloadcenter) (1).

Threaded lifting pins are designed to lift and hold point loads (**not people!!**).

Threaded lifting pins are **not suited for the rotation of the load**.

Soilings (e.g. grits and grinds, oil and emulsion deposits, dust ...) can affect the functioning of the threaded lifting pins.

Using damaged threaded lifting pins can be perilous. **Before any use** carefully inspect the threaded lifting pins (i.e. deformities, breaks, rips, damages, missing threaded elements, corrosion, unlocking function). **Threaded lifting pins must be screwed completely into a thread that is true to gauge and bear completely on the bearing surface.** When inserting a threaded lifting pin, the rotation of the load must be prevented. **Please avoid direct impacts to the threaded lifting pins also if those are not in use.**

**Damaged threaded lifting pins must be withdrawn from service immediately.**

It is prohibited:

- to mark the threaded lifting pins in colour (especially red)
- to use the threaded lifting pins after exceeding 16,000 load cycles

The operation as well as work on the threaded lifting pins may only be carried out by qualified or instructed personnel. The threaded lifting pins may only be put into operation and serviced after the original operating instructions have been read.

**Handling and Stress**

To release the threaded elements, press button (A). To lock the threaded elements, release button (A). **Threaded lifting pins must be screwed in completely.**

**Attention:** The button (A) is locked after springing back to the initial position by means of the spring resistance.

Do **not** operate the button at charge.

The stress figures  $F_1 / F_2 / F_3$  (see page 2) apply only to lifting applications with a steel retainer.

**Maintenance:**

Threaded lifting pins must be taken out of service for proper inspection by a qualified person(s) at least once a year.

**Visual inspection:**

Grits and grinds, breaks, rips, missing and damaged threaded elements, corrosion, screw union damages at shackle.

**Performance check:**

- the threaded elements must be locked automatically by the spring force
- full movement of the shackle must be ensured



(1) Original operating instructions

FR: La traduction dans votre langue de cet manuel d'instruction succinct et de la déclaration de conformité est disponible sur [www.halder.com](http://www.halder.com)

IT: La traduzione di questo breve manuale di istruzioni nella vostra lingua con la Dichiarazione di conformità è disponibile nel sito [www.halder.com](http://www.halder.com).

ES: La traducción de este breve manual de instrucciones en su idioma con la Declaración de conformidad está disponible en [www.halder.com](http://www.halder.com).

CZ: Překlad tohoto krátkého návodu ve vašem jazyce s prohlášením o shodě je k dispozici na [www.halder.com](http://www.halder.com).

RO: Acest scurt instructaj de utilizare, tradus în limba dumneavoastră, împreună cu Declarația de conformitate sunt disponibile pentru descărcare pe [www.halder.com](http://www.halder.com).

PL: Tłumaczenie tej krótkiej instrukcji obsługi na Twój język wraz z deklaracją zgodności jest dostępne na stronie [www.halder.com](http://www.halder.com).

FI: Tämän lyhyen käyttöohjeen käänös omalla kielelläsi ja vaatimustenmukaisuusvakuutus ovat saatavilla osoitteessa [www.halder.com](http://www.halder.com).

SE: En översättning av denna korta instruktionsmanual med försäkran om överensstämmelse finns på ditt spark att hämta på [www.halder.com](http://www.halder.com).

NL: De vertaling van deze korte handleiding in uw eigen taal met conformiteitsverklaring is beschikbaar op [www.halder.com](http://www.halder.com).

KR: 적합선 선언과 함께 귀하의 언어로 번역이 된 짧은 설명서는 [www.halder.com](http://www.halder.com)에서 확인 가능합니다.

CN: 可在 [www.halder.com](http://www.halder.com) 上获得带有符合性声明的此简短说明手册的翻译版本。

TW: 可在 [www.halder.com](http://www.halder.com) 上獲得帶有符合性聲明的此簡短說明手冊的翻譯版本。

JP: CE準拠の宣言書は、取扱説明書に付属していますが、以下URLでダウンロードできます [www.halder.com](http://www.halder.com)。

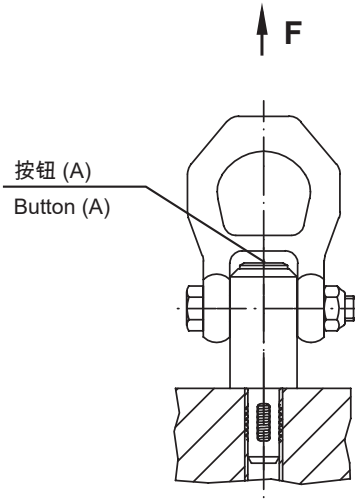

尺寸 / Dimensions													负载能力 根据 DIN EN 13155 / Load capacity according to DIN EN 13155			定位螺纹 / Locating thread	🌡️	📦	品号 / Art. No.	
d <sub>1</sub>	l <sub>1</sub>	d <sub>2</sub> -0,0028	d <sub>3</sub>	l <sub>2</sub>	l <sub>3</sub>	l <sub>4</sub>	l <sub>5</sub>	l <sub>6</sub>	l <sub>7</sub>	l <sub>8</sub>	l <sub>9</sub>	l <sub>10</sub>	F <sub>1</sub>	F <sub>2</sub>	F <sub>3</sub>		max.		热处理钢 / Heat-treated steel	不锈钢 / Stainless steel
[英寸/inch]													[lbf]			[英寸/inch]	[°F]	[oz]		
1/2-13	0,669	0,416	0,846	0,945	1,012	1,417	1,063	1,181	1,929	3,445	0,846	0,472	1,528	764	607	1/2-13	482	9,830	2B352.0012	2B352.1012
3/4-10	0,866	0,640	1,181	1,181	1,437	2,047	1,283	1,417	2,205	4,488	1,181	0,669	3,619	1,731	1,281	3/4-10	482	18,080	2B352.0020	-
3/4-10	0,866	0,640	1,181	1,181	1,437	2,047	1,283	1,417	2,205	4,488	1,181	0,669	2,248	1,731	1,281	3/4-10	482	18,080	-	2B352.1020
1-8	1,063	0,863	1,417	1,417	1,654	2,362	1,992	1,961	2,228	5,984	1,417	0,866	6,766	3,147	2,225	1-8	482	42,153	2B352.0024	2B352.1024

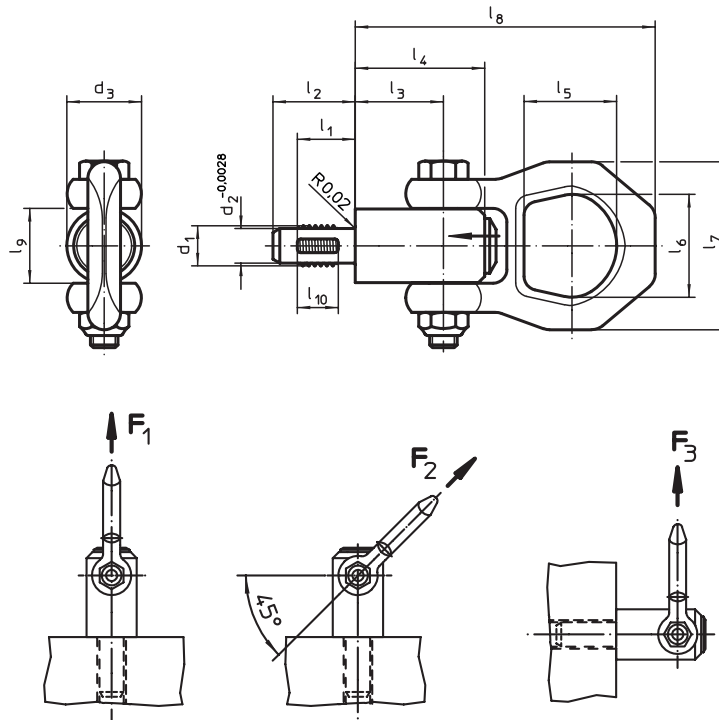

## EC一致性声明 / EC Declaration of conformity

此产品符合 EC 指令 2006/42/EC.

This product is conform with the EC Directive 2006/42/EC.

制造商 / Manufacturer: \*

Erwin Halder KG

地址 / Address: \*

Erwin-Halder-Strasse 5 - 9

\* 对文件负责 /  
responsible for documentation

88480 Achstetten-Bronnen / Germany

产品 / Product:

螺纹顶上销 / Threaded lifting pins

类型 / Type:

EH 2B352.

申请标准 /

DIN EN 13155:2020

Applied standard:

专利 / Patent:

US 11649847 B2



Achstetten-Bronnen, 2024 年 2 月

*S. Halder*  
Stefan Halder, 总经理 / General Manager