

绞链 · Zinc die-cast, with spring return

EH 25163.

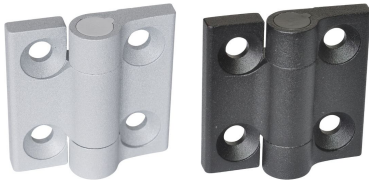

产品描述

Hinges from zinc die-cast with spring return allow doors to be automatically opened or closed. The torque of the reset depends on the opening angle of the hinge (refer to the drawing). Endurance tests have shown that the torque of the reset does not change even after 100,000 cycles. These hinges from zinc die-cast are characterised by their simple and timeless design.

材质

本体

- 锌压铸, 表面涂装, 银色, 类似 RAL 9006, 雾面
- 锌合金压铸、塑料涂层、黑色, 近似 RAL 9005 亚光结构

弹簧

- 弹簧钢丝

复盖

- 得林塑料

更多信息

更多产品

- 分隔板, 用于绞链
- 螺紋板, 用于绞链

图面

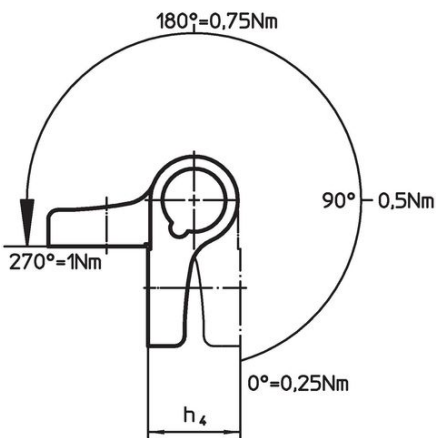
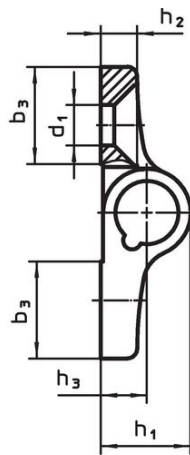
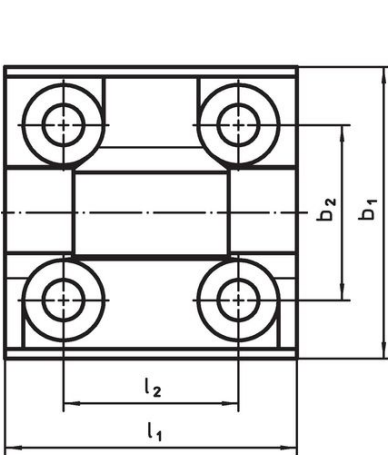

图片 1

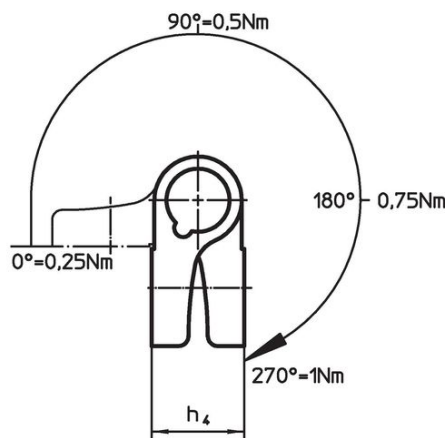

图片 2

订单信息

					尺寸					max. [°C]	[g]	品号
b ₁	l ₁	b ₂	b ₃	d ₁	h ₁ [mm]	h ₂	h ₃	h ₄	l ₂			
spring-loaded return closing – 相片 1, 锌压铸, 银												
60	60	36	20	8,3	18,5	7,5	9,5	19	36	80	149	25163.0010
spring-loaded return closing – 相片 1, 锌压铸, 黑色												
60	60	36	20	8,3	18,5	7,5	9,5	19	36	80	149	25163.0110
spring-loaded return opening – 相片 2, 锌压铸, 银												
60	60	36	20	8,3	18,5	7,5	9,5	19	36	80	146	25163.0015
spring-loaded return opening – 相片 2, 锌压铸, 黑色												
60	60	36	20	8,3	18,5	7,5	9,5	19	36	80	146	25163.0115

遵守

符合 RoHS

符合指令 2011/65/EU 和指令 2015/863

不含 SVHC 物质

不含超过 0.1% w/w 的 SVHC 物质 - 截至 2024 年 6 月 27 日的 SVHC 清单.

不含 65 号提案物质

不包括 65 号提案物质

<https://www.P65Warnings.ca.gov/>

不含冲突矿物

„本产品不含来自刚果民主共和国或邻近国家的任何被指定为“冲突矿物”的物质，例如钽、锡、金或钨。