

橡胶金属缓冲器 · 圆柱形止位块

EH 25150.



产品描述

用在马达橡皮轴承, 压缩机, 泵浦等。
硬度为55 - 5°A。硬度 (40 - 5°邵氏A和70 - 5°邵氏A) 的要求。

材质

轴承垫片

- 钢, 镀锌, 铬化蓝

螺纹衬套

- 钢, 镀锌, 铬化蓝

本体

- 天然生橡胶, 黑色

螺丝

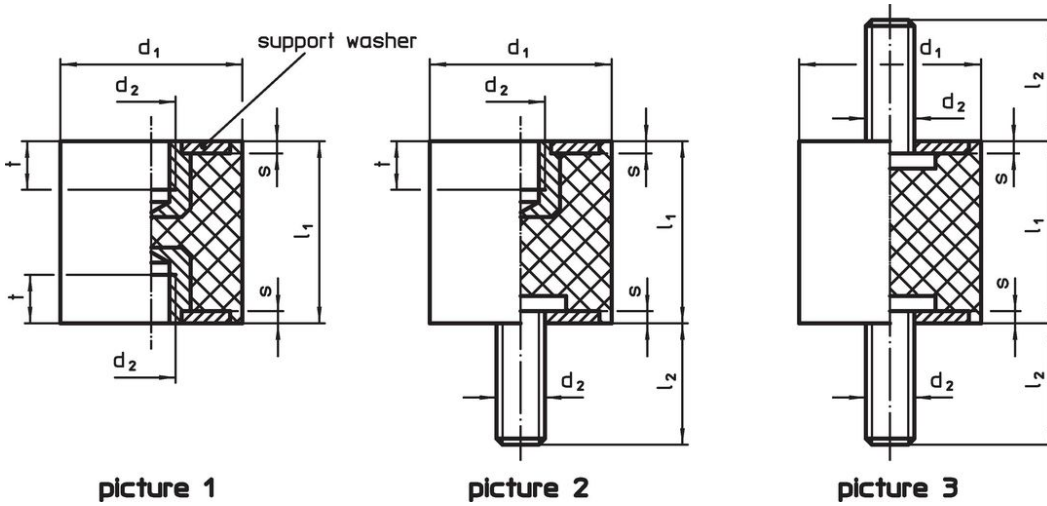

- 钢, 镀锌, 铬化蓝

图面



订单信息

尺寸						弹簧比率 R ~ [N/mm]	荷重能力 max. [N]	弹簧范围 ~ [mm]	温度		重量 [g]	品号
d ₁ ±1,5	l ₁ ±1,5	d ₂	l ₂	s	t ~				min	max.		
[mm]									[°C]			
带有母螺纹在两端 - 相片 1												
8	8	M 3	-	1,0	3,0	38	75	2,00	-30	80	1,0	25150.0003
10	10	M 4	-	1,2	4,0	36	90	2,50	-30	80	2,5	25150.0006
10	15	M 4	-	1,2	4,0	17	65	3,75	-30	80	2,9	25150.0007
15	10	M 4	-	1,4	4,0	80	200	2,50	-30	80	5,2	25150.0008
15	15	M 4	-	1,4	4,0	36	135	3,75	-30	80	6,2	25150.0009
15	20	M 4	-	1,4	4,0	30	152	5,00	-30	80	7,4	25150.0010
20	15	M 6	-	2,0	5,0	95	355	3,75	-30	80	13,0	25150.0021
20	20	M 6	-	2,0	5,0	53	267	5,00	-30	80	14,0	25150.0022
20	25	M 6	-	2,0	5,0	50	315	6,25	-30	80	16,0	25150.0023
25	20	M 6	-	2,0	5,0	121	605	5,00	-30	80	22,0	25150.0026
25	25	M 6	-	2,0	5,0	85	530	6,25	-30	80	30,0	25150.0027
25	30	M 6	-	2,0	5,0	77	575	7,50	-30	80	30,0	25150.0028
30	30	M 8	-	2,0	6,5	114	855	7,50	-30	80	50,0	25150.0031
30	40	M 8	-	2,0	6,5	76	757	10,00	-30	80	50,0	25150.0032
40	30	M 8	-	2,0	6,5	205	1535	7,50	-30	80	80,0	25150.0041
40	40	M 8	-	2,0	6,5	164	1635	10,00	-30	80	100,0	25150.0042
50	30	M10	-	2,0	7,0	343	2570	7,50	-30	80	130,0	25150.0051
50	40	M10	-	2,0	7,0	245	2445	10,00	-30	80	150,0	25150.0052

尺寸						弹簧比率 R ~ [N/mm]	荷重能力 max. [N]	弹簧范围 ~ [mm]	 min max. [°C]		 [g]	品号
d ₁ ±1,5	l ₁ ±1,5	d ₂	l ₂	s	t ~				[mm]			
50	50	M10	-	2,0	7,0	178	2225	12,50	-30	80	166,0	25150.0053
60	30	M10	-	2,0	7,0	453	3400	7,50	-30	80	190,0	25150.0061
60	40	M10	-	2,0	7,0	330	3300	10,00	-30	80	220,0	25150.0062
70	45	M10	-	3,0	7,0	356	4000	11,25	-30	80	340,0	25150.0071
75	40	M12	-	3,0	9,0	465	4650	10,00	-30	80	360,0	25150.0076
75	55	M12	-	3,0	9,0	327	4500	13,75	-30	80	450,0	25150.0077
适用于下列尺寸的组立工具 - 相片 2												
8	8	M 3	6	1,0	3,0	38	75	2,00	-30	80	1,2	25150.0103
10	10	M 4	10	1,2	4,0	36	90	2,50	-30	80	2,4	25150.0106
10	15	M 4	10	1,2	4,0	17	65	3,75	-30	80	2,8	25150.0107
15	10	M 4	10	1,4	4,0	80	200	2,50	-30	80	5,7	25150.0108
15	15	M 4	10	1,4	4,0	35	130	3,75	-30	80	6,6	25150.0109
15	20	M 4	10	1,4	4,0	30	150	5,00	-30	80	7,6	25150.0110
20	15	M 6	18	2,0	5,0	95	355	3,75	-30	80	15,0	25150.0121
20	20	M 6	18	2,0	5,0	53	265	5,00	-30	80	17,0	25150.0122
20	25	M 6	18	2,0	5,0	50	315	6,25	-30	80	18,0	25150.0123
25	15	M 6	18	2,0	5,0	184	690	3,75	-30	80	26,0	25150.0126
25	20	M 6	18	2,0	5,0	121	605	5,00	-30	80	26,0	25150.0127
25	30	M 6	18	2,0	5,0	76	570	7,50	-30	80	36,0	25150.0128
30	15	M 8	20	2,0	6,5	143	535	3,75	-30	80	41,0	25150.0131
30	30	M 8	20	2,0	6,5	113	850	7,50	-30	80	50,0	25150.0132
40	20	M 8	23	2,0	6,5	302	1510	5,00	-30	80	72,0	25150.0141
40	30	M 8	23	2,0	6,5	204	1530	7,50	-30	80	85,0	25150.0142
40	40	M 8	23	2,0	6,5	163	1630	10,00	-30	80	98,0	25150.0143
50	20	M10	28	2,0	7,0	720	3600	5,00	-30	80	115,0	25150.0151
50	30	M10	28	2,0	7,0	343	2575	7,50	-30	80	135,0	25150.0152
50	40	M10	28	2,0	7,0	244	2440	10,00	-30	80	160,0	25150.0153
50	50	M10	28	2,0	7,0	176	2200	12,50	-30	80	185,0	25150.0154
60	30	M10	28	2,0	7,0	453	3400	7,50	-30	80	200,0	25150.0161
60	40	M10	28	2,0	7,0	333	3330	10,00	-30	80	220,0	25150.0162
70	45	M10	27	3,0	7,0	356	4000	11,25	-30	80	372,0	25150.0171
75	40	M12	37	3,0	9,0	460	4600	10,00	-30	80	385,0	25150.0176
75	55	M12	37	3,0	9,0	328	4510	13,75	-30	80	453,0	25150.0177
带有螺丝在两端 - 相片 3												
8	8	M 3	6	1,0	-	35	70	2,00	-30	80	1,4	25150.0203
10	10	M 4	10	1,2	-	36	89	2,50	-30	80	3,0	25150.0206
10	15	M 4	10	1,2	-	16	60	3,75	-30	80	3,5	25150.0207
15	10	M 4	10	1,4	-	79	198	2,50	-30	80	6,1	25150.0208
15	15	M 4	10	1,4	-	33	125	3,75	-30	80	7,1	25150.0209
15	20	M 4	10	1,4	-	29	145	5,00	-30	80	8,1	25150.0210
20	15	M 6	18	2,0	-	94	352	3,75	-30	80	18,0	25150.0221
20	20	M 6	18	2,0	-	52	260	5,00	-30	80	19,0	25150.0222
20	25	M 6	18	2,0	-	50	310	6,25	-30	80	20,0	25150.0223
25	15	M 6	18	2,0	-	183	687	3,75	-30	80	28,0	25150.0226
25	20	M 6	18	2,0	-	120	602	5,00	-30	80	32,0	25150.0227
25	30	M 6	18	2,0	-	75	562	7,50	-30	80	39,0	25150.0228
30	15	M 8	20	2,0	-	142	534	3,75	-30	80	45,0	25150.0231
30	30	M 8	20	2,0	-	112	843	7,50	-30	80	58,0	25150.0232
40	20	M 8	23	2,0	-	300	1500	5,00	-30	80	80,0	25150.0241
40	30	M 8	23	2,0	-	204	1527	7,50	-30	80	95,0	25150.0242
40	40	M 8	23	2,0	-	162	1620	10,00	-30	80	100,0	25150.0243
50	20	M10	28	2,0	-	718	3589	5,00	-30	80	130,0	25150.0251
50	30	M10	28	2,0	-	343	2570	7,50	-30	80	150,0	25150.0252
50	40	M10	28	2,0	-	244	2436	10,00	-30	80	170,0	25150.0253
50	50	M10	28	2,0	-	176	2198	12,50	-30	80	187,0	25150.0254
60	30	M10	28	2,0	-	453	3400	7,50	-30	80	210,0	25150.0261
60	40	M10	28	2,0	-	330	3300	10,00	-30	80	236,0	25150.0262
70	45	M10	27	3,0	-	356	4000	11,25	-30	80	380,0	25150.0271
75	40	M12	37	3,0	-	450	4500	10,00	-30	80	410,0	25150.0276
75	55	M12	37	3,0	-	320	4400	13,75	-30	80	515,0	25150.0277

应用范例

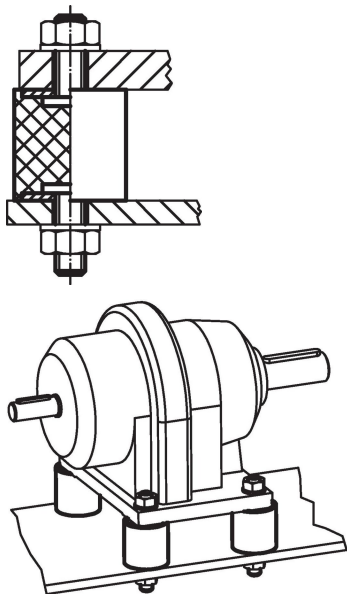

遵守

符合 RoHS

含铅 - 符合例外 6a / 6b / 6c

含有 >0.1% w/w 的 SVHC 物质

含铅 - SVHC [REACH] 清单截至 2024 年 1 月 23 日

包含 65 号提案的物质



铅暴露会导致癌症和生殖伤害

<https://www.P65Warnings.ca.gov/>

不含冲突矿物

„本产品不含来自刚果民主共和国或邻近国家的任何被指定为“冲突矿物”的物质，例如钽、锡、金或钨。