

螺旋千斤顶 EH 23470.



产品描述

梯形自锁式螺纹组件。含有最终安全装置之心轴。支撑组件这类可藉由T形槽加以固定的组件，可用以固定千斤顶，使其不致于在更换工件时滑离定位。此外，可用以将螺旋型千斤顶固定于垂直的固夹面上，而螺旋型千斤顶通常系用于工件的支撑。自我对准型盖子的使用可确保支承面的正确对准。将对中定位板作为中间组件时，可将 52、70 及 100 等尺寸的螺旋型千斤顶上下固定在一起。

材质

自校调整盖

- 钢，表面硬化，染黑

托座

- 钢，染黑

螺旋千斤顶

- 钢1.0503亮漆



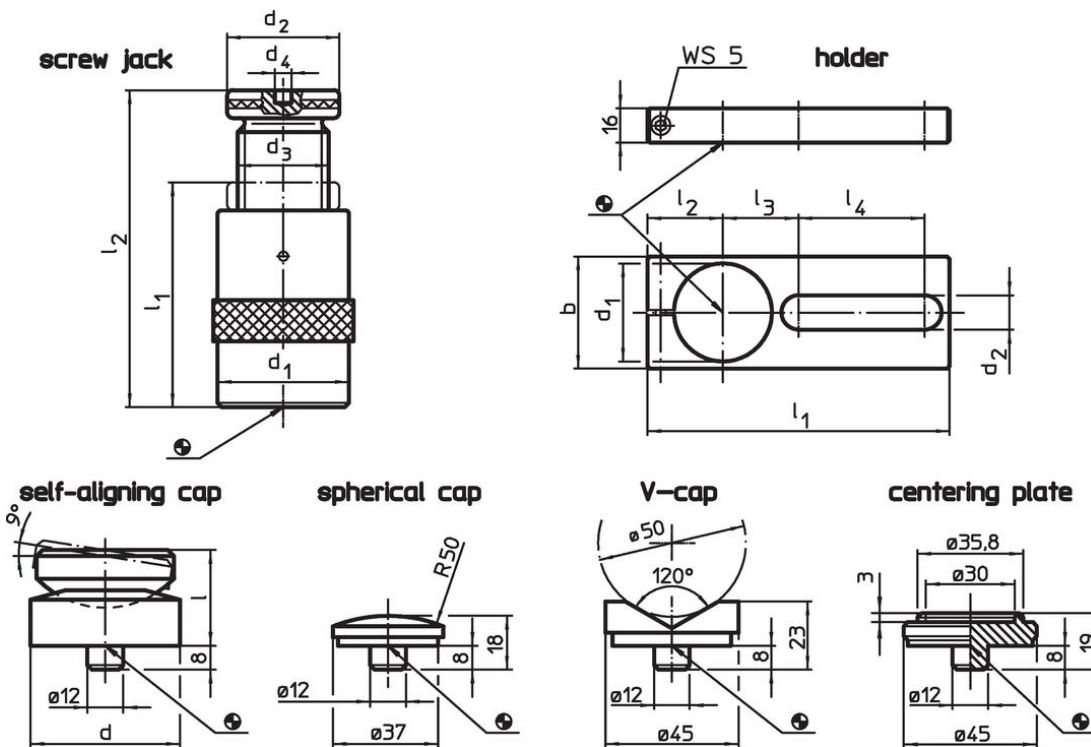



图面



订单信息

l ₂ 夹持高度 max. [mm]	l ₁ min	尺寸				d ₄ [mm]	荷重能力 [kN]	[g]	品号
		d ₁ [mm]	d ₂	d ₃					
千斤顶									
50	38	31	31	Tr 20 x 4		-	15	191	23470.0005
52	42	50	50	Tr 30 x 4		12	60	539	23470.0006
70	50	50	50	Tr 30 x 4		12	60	645	23470.0007
100	70	50	50	Tr 30 x 4		12	60	900	23470.0010
140	100	69	69	Tr 40 x 7		12	100	2614	23470.0014
210	140	80	70	Tr 50 x 8		12	170	4336	23470.0021
300	190	100	80	Tr 65 x 10		12	350	9680	23470.0030

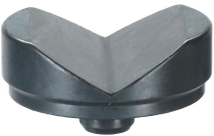
配件

	d	d ₁	b	尺寸						螺丝千斤顶 [mm]	 [g]	品号
				d ₂	l	l ₁	l ₂	l ₃	l ₄			
[mm]												
托座												
	-	31	40	18,5	-	175	30	35	90	50	516	23470.0232
	-	50	60	20,5	-	190	38	46	90	52/ 70/100	879	23470.0250
	-	69	80	24,5	-	210	48	54	90	140	1279	23470.0270
自行校准盖												
	50	-	-	-	32	-	-	-	-	52/ 70/100	399	23470.0350
	65	-	-	-	35	-	-	-	-	140/210	716	23470.0365
球形形盖												
	-	-	-	-	-	-	-	-	-	52/ 70/100/140/210/300	75	23470.0171
V型盖												
	-	-	-	-	-	-	-	-	-	52/ 70/100/140/210/300	138	23470.0172
中心板												
	-	-	-	-	-	-	-	-	-	52/ 70/100	107	23470.0170

遵守

For detailed compliance information please select the desired article number.