

推拉夹具  
EH 23229.



产品描述

夹具适于在夹紧或组装之前容易和安全地定位工件或部件。  
当推/拉夹具在两侧都有螺纹时，可以固定适合于工件的元件，例如，棱镜，夹紧螺栓，自对准垫。

材质

螺絲形支撐座

- 钢，染黑

本体

- 钢，镀锌

弹簧

- 不锈钢 1.4310

图面

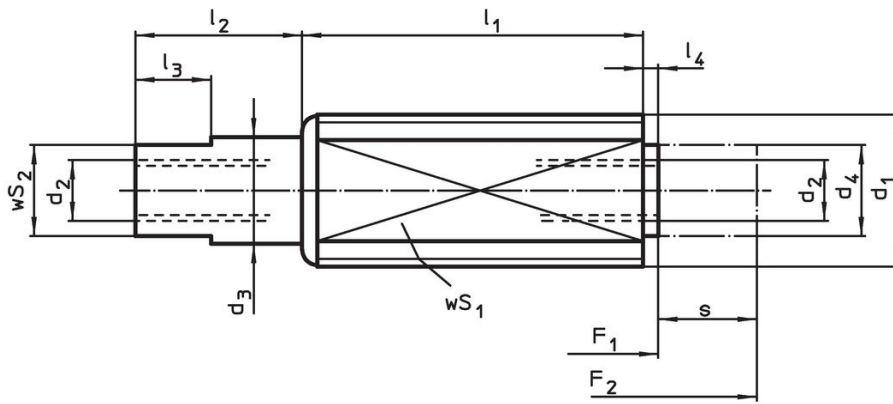

订单信息

d <sub>1</sub>	d <sub>2</sub>	d <sub>3</sub>	尺寸				行程 s ~ [mm]	WS		弹簧荷重		[g]	品号	
			d <sub>4</sub> [mm]	l <sub>1</sub> -1	l <sub>2</sub> ±0,5	l <sub>3</sub>		l <sub>4</sub> -0,5	WS <sub>1</sub> [mm]	WS <sub>2</sub> [mm]	F <sub>1</sub> ~ [N]			F <sub>2</sub> ~ [N]
<b>轻弹簧荷重</b>														
M12	M4 x 8	7	6	11,0	4,5	5	1,5	3,5	10	6	5	20	5,1	23229.0005
M12	M4 x 8	7	6	18,5	7,0	5	1,5	6,0	10	6	5	20	8,7	23229.0010
M12	M4 x 8	7	6	26,0	11,0	5	1,5	10,0	10	6	5	20	13,0	23229.0015
<b>标准弹簧荷重</b>														
M12	M4 x 8	7	6	11,0	4,5	5	1,5	3,0	10	6	10	45	5,3	23229.0020
M12	M4 x 8	7	6	18,5	7,0	5	1,5	5,0	10	6	10	45	8,7	23229.0025
M12	M4 x 8	7	6	26,0	11,0	5	1,5	8,0	10	6	10	45	14,0	23229.0030
M18 x 1,5	M6 x 12	11	10	18,0	6,0	6	2,0	4,0	16	9	30	120	22,0	23229.0050
M18 x 1,5	M6 x 12	11	10	31,5	11,5	6	2,0	7,0	16	9	30	120	42,0	23229.0055
M18 x 1,5	M6 x 12	11	10	45,0	16,0	6	2,0	12,5	16	9	60	180	63,0	23229.0060
<b>重弹簧荷重</b>														
M12	M4 x 8	7	6	11,0	4,5	5	1,5	3,0	10	6	20	90	5,4	23229.0035
M12	M4 x 8	7	6	18,5	7,0	5	1,5	5,0	10	6	20	90	9,0	23229.0040
M12	M4 x 8	7	6	26,0	11,0	5	1,5	8,0	10	6	20	90	14,0	23229.0045

## 应用范例

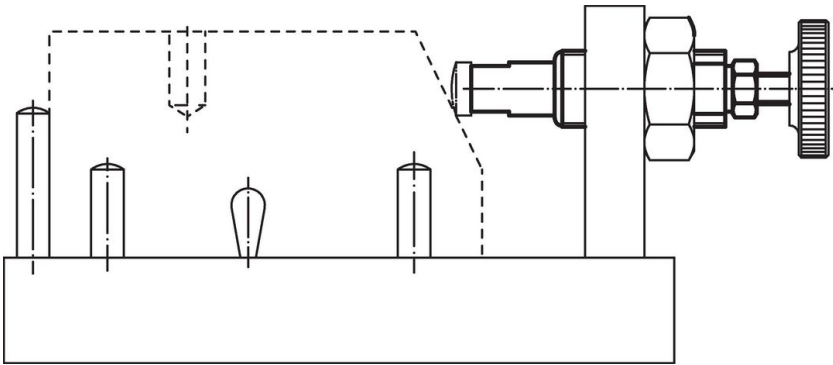

## 遵守

### 符合 RoHS

含铅 - 符合例外 6a / 6b / 6c

### 含有 >0.1% w/w 的 SVHC 物质

含铅 - SVHC [REACH] 清单截至 2024 年 6 月 27 日

### 包含 65 号提案的物质



铅暴露会导致癌症和生殖伤害

<https://www.P65Warnings.ca.gov/>

### 不含冲突矿物

„本产品不含来自刚果民主共和国或邻近国家的任何被指定为“冲突矿物”的物质，例如钽、锡、金或钨。