

压板 · 有鼻  
EH 23180.



产品描述

This clamp (clamping claw) with nose is mainly used in mechanical clamping technology for clamping workpieces.

材质

- 钢, 热处理, 染黑

图面

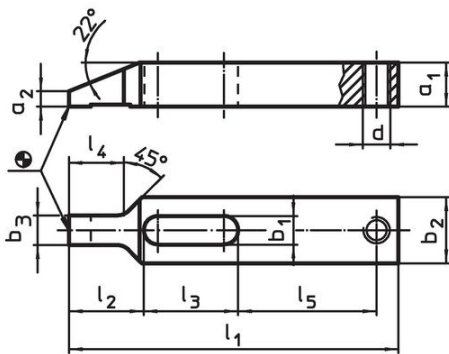

picture 1

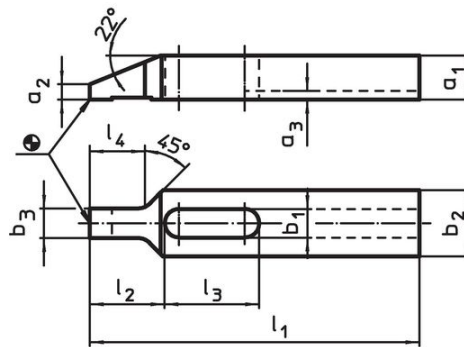

picture 2

订单信息

标称不清。 b <sub>1</sub> [mm]	l <sub>1</sub>	a <sub>1</sub>	a <sub>2</sub>	a <sub>3</sub>	b <sub>2</sub>	尺寸 [mm]						重量 [g]	品号	
						b <sub>3</sub>	d	l <sub>2</sub>	l <sub>3</sub>	l <sub>4</sub>	l <sub>5</sub>			
<b>有牙 适合于调整式 螺丝 – 相片 1</b>														
6,6	80	8	2,5	–	15	7,5	M 6	17	23	13	34	54	23180.0107	
9,0	100	12	4,0	–	20	9,5	M 8	22	29	17	42	133	23180.0109	
11,0	125	15	5,0	–	25	11,5	M10	28	36	21	52	261	23180.0111	
13,0	150	20	7,0	–	30	13,5	M12	34	43	25	63	504	23180.0113	
17,0	175	25	9,0	–	35	15,5	M16	40	52	29	70	828	23180.0117	
<b>有键槽 – 相片 2</b>														
6,6	80	8	2,5	2,5	15	7,5	–	17	23	13	–	50	23180.0207	
9,0	100	12	4,0	3,0	20	9,5	–	22	29	17	–	127	23180.0209	
11,0	125	15	5,0	3,5	25	11,5	–	28	36	21	–	251	23180.0211	
13,0	150	20	7,0	4,0	30	13,5	–	34	43	25	–	488	23180.0213	
17,0	175	25	9,0	4,5	35	15,5	–	40	52	29	–	812	23180.0217	
22,0	225	35	15,5	5,5	50	19,5	–	52	62	33	–	2200	23180.0222	
26,0	250	40	17,5	5,5	60	21,5	–	60	71	36	–	3340	23180.0226	

## 应用范例

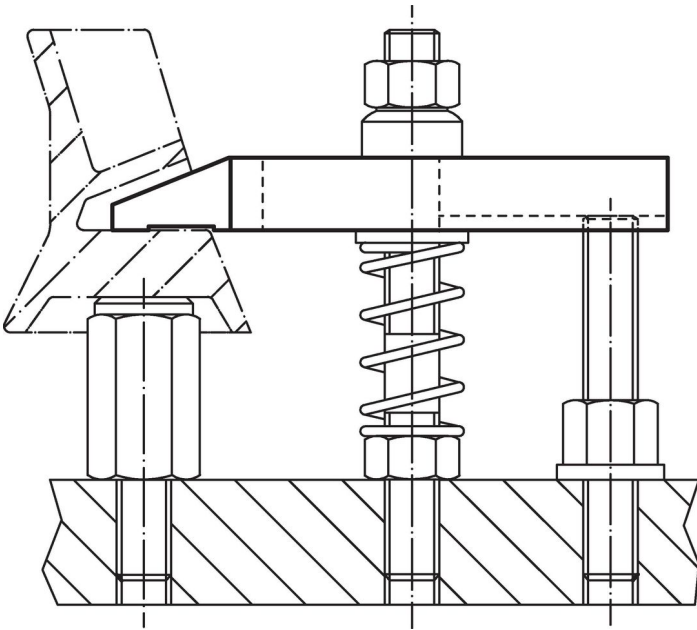

## 遵守

### 符合 RoHS

符合指令 2011/65/EU 和指令 2015/863

### 不含 SVHC 物质

不含超过 0.1% w/w 的 SVHC 物质 - 截至 2024 年 1 月 23 日的 SVHC 清单。

### 不含 65 号提案物质

不包括 65 号提案物质

<https://www.P65Warnings.ca.gov/>

### 不含冲突矿物

„本产品不含来自刚果民主共和国或邻近国家的任何被指定为“冲突矿物”的物质，例如钽、锡、金或钨。