

压板 · DIN 6314 平
EH 23140.



产品描述

This clamp (clamping claw) according to DIN 6314 is mainly used in mechanical clamping technology for clamping workpieces.

材质

- 热处理钢，亮漆

图面

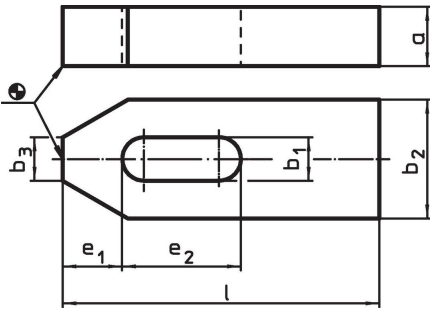

订单信息

标称不清。 b ₁ [mm]	尺寸						螺丝用		重量 [g]	品号
	l	a	b ₂ [mm]	b ₃	e ₁	e ₂	[mm]	[英寸]		
6,6	50	10	20	8	10	20	M 6	1/4	61	23140.0007
9,0	60	12	25	10	13	22	M 8	5/16	112	23140.0009
11,0	80	15	30	12	15	30	M10	3/8	228	23140.0011
14,0	100	20	40	14	21	40	M12, M14	1/2	492	23140.0014
14,0	125	20	40	14	21	50	M12, M14	1/2	623	23140.0015
18,0	125	25	50	18	26	45	M16, M18	5/8	980	23140.0018
18,0	160	25	50	18	26	65	M16, M18	5/8	1246	23140.0019
22,0	160	30	60	22	30	60	M20, M22	3/4	1793	23140.0022
22,0	200	30	60	22	30	80	M20, M22	3/4	2244	23140.0023
26,0	200	30	70	26	35	80	M24	1	2617	23140.0026
26,0	250	30	70	26	35	105	M24	1	3823	23140.0027
33,0	250	40	80	34	45	100	M30	1 1/4	4980	23140.0034
33,0	315	50	80	34	45	130	M30	1 1/4	7840	23140.0035

应用范例

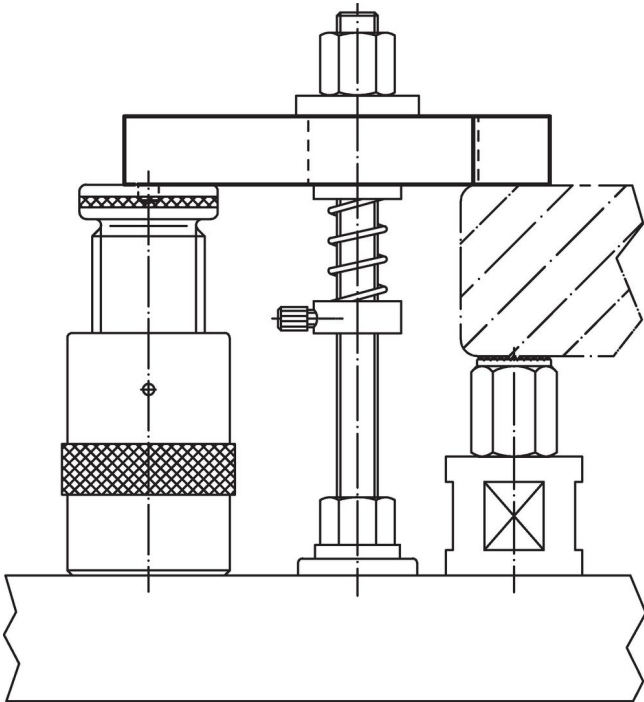

遵守

符合 RoHS

符合指令 2011/65/EU 和指令 2015/863

不含 SVHC 物质

不含超过 0.1% w/w 的 SVHC 物质 - 截至 2024 年 6 月 27 日的 SVHC 清单.

不含 65 号提案物质

不包括 65 号提案物质

<https://www.P65Warnings.ca.gov/>

不含冲突矿物

„本产品不含来自刚果民主共和国或邻近国家的任何被指定为“冲突矿物”的物质，例如钽、锡、金或钨。