

轴环螺帽附圆锥型座

EH 23080.



产品描述

此种组合可弥补不规则表面的不足。

The fixture nut with conical seat is a fixed unit consisting of fixture nut and conical seat with the following advantages / characteristics:

- Functionally reliable
- Captive
- Fast and efficient mounting
- Simplified storage
- Swivel range max. 3°

材质

锥形座

- 钢，热处理， 染黑

螺帽

- 钢，热处理， 染黑

更多信息

参考

有关起始扭力和稳定性请参考附件 - 技术数据

图面

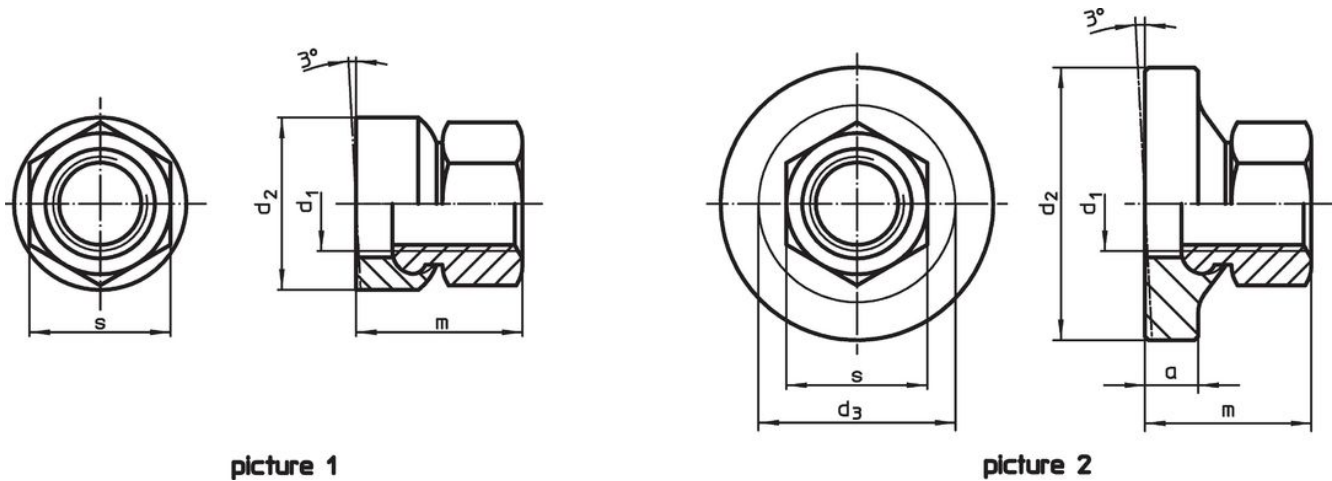

picture 1

picture 2

订单信息

d ₁	a	尺寸 d ₂ [mm]	d ₃	m ~	s [mm]	 [g]	品号
具有小表面 - 相片 1							
M 8	-	17	-	14,0	13	13	23080.0508
M10	-	21	-	17,5	16	24	23080.0510
M12	-	24	-	21,5	18	37	23080.0512
M16	-	30	-	28,0	24	73	23080.0516
M20	-	36	-	35,0	30	141	23080.0520
M24	-	44	-	42,5	36	259	23080.0524
M30	-	55	-	56,0	46	544	23080.0530
具有大表面 - 相片 2							
M 8	4,0	24	17,8	14,0	13	20	23080.0608
M10	5,5	30	21,2	17,5	16	39	23080.0610
M12	7,0	36	25,2	21,5	18	68	23080.0612
M16	8,0	44	30,9	28,0	24	124	23080.0616
M20	9,5	50	39,9	35,0	30	213	23080.0620
M24	11,0	60	49,6	42,5	36	378	23080.0624
M30	14,0	68	61,3	56,0	46	691	23080.0630

应用范例



遵守

For detailed compliance information please select the desired article number.