

活节螺栓 · DIN 444 , 形式B , quality 8.8
EH 22980.



产品描述

高精度设计的活节螺栓超越 DIN 版本的品质。转造牙-轴径等于滚动径。表面-s-已处理加工孔的公差 $d_2 = H7$ 。

材质

- 热处理钢, quality 8.8 , 黑色

更多信息

参考

有关起始扭力请参考附件 - 技术数据 -

更多产品

- 活节螺栓, DIN 444, 型式 B

图面

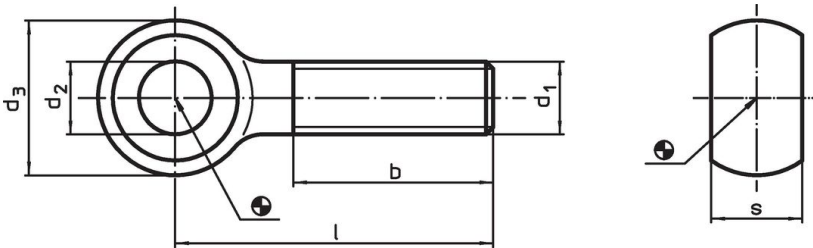

订单信息

d ₁	l	尺寸				s -0,2	[g]	品号
		d ₂ H7 [mm]	d ₃	b				
M 8	40	8	18	22	9	28	22980.0081	
M 8	60	8	18	22	9	28	22980.0084	
M10	50	10	20	26	12	38	22980.0103	
M10	75	10	20	26	12	50	22980.0106	
M10	100	10	20	26	12	62	22980.0108	
M12	60	12	25	30	14	70	22980.0122	
M12	80	12	25	30	14	84	22980.0125	
M12	120	12	25	30	14	113	22980.0128	
M16	80	16	32	38	17	153	22980.0163	
M16	150	16	32	44	17	245	22980.0168	

应用范例

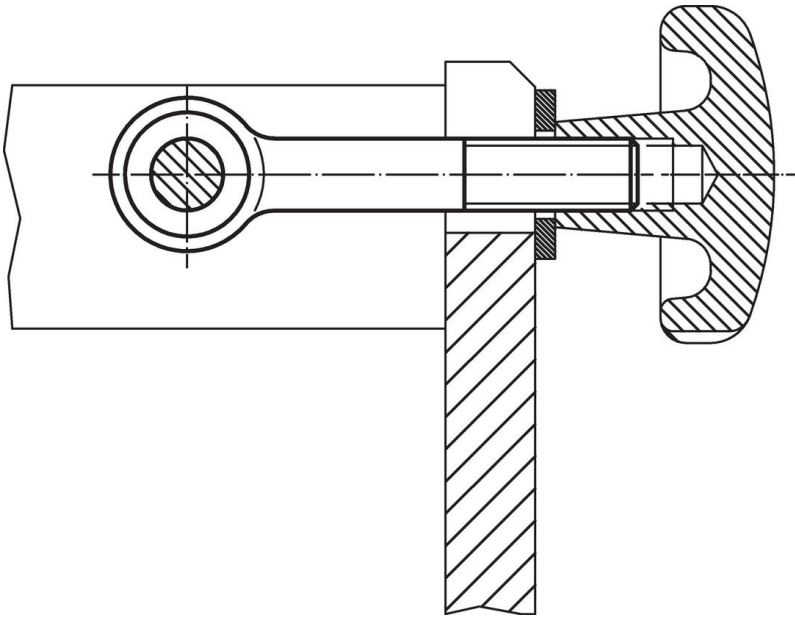

遵守

For detailed compliance information please select the desired article number.