

## 距离调整环 · 适用于分割定位柱

EH 22120.



### 产品描述

定距轴环调整分割定位柱的螺丝长度以适应不同螺纹长度。

### 材质

- 不锈钢 1.4305

### 图面

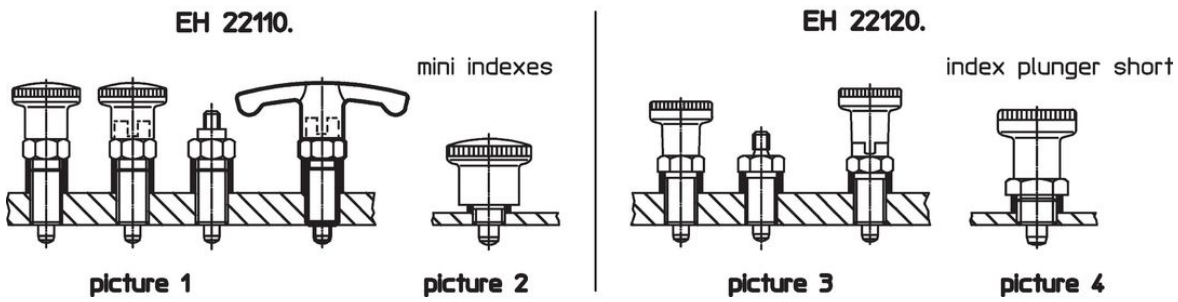

### 订单信息

d <sub>1</sub> H12	尺寸		用于分割定位柱 [mm]	用于最后加工	max. [°C]	[g]	品号
	l ±0,1 [mm]	d <sub>2</sub> -0,1					
8	2	10	M 8	1/2	250	0,4	22120.0632
8	3	10	M 8	1	250	0,8	22120.0633
8	4	10	M 8	1	250	0,9	22120.0634
8	6	10	M 8	1	250	1,2	22120.0636
8	8	10	M 8	1	250	2,0	22120.0638
8	10	10	M 8	1	250	2,0	22120.0640
10	2	12	M10	1/2/3	250	0,6	22120.0642
10	4	12	M10	1/2/3	250	1,1	22120.0644
10	6	12	M10	1/3	250	1,6	22120.0646
10	8	12	M10	1/3	250	2,1	22120.0648
10	10	12	M10	1/3	250	2,7	22120.0650
10	12	12	M10	1/3	250	3,0	22120.0652
12	2	14	M12	1	250	0,6	22120.0662
12	4	14	M12	1	250	2,5	22120.0664
12	6	14	M12	1	250	1,9	22120.0666
12	8	14	M12	1	250	2,4	22120.0668
12	2	17	M12	3/4	250	2,0	22120.0672
12	4	17	M12	3/4	250	3,4	22120.0674
12	5	17	M12	3/4	250	4,4	22120.0675
16	4	17	M16	1	250	0,9	22120.0676

d <sub>1</sub> H12	尺寸		用于分割定位柱 [mm]	用于最后加工	🌡️ max. [°C]	🏋️ [g]	品号
	l ±0,1 [mm]	d <sub>2</sub> -0,1					
16	6	17	M16	1	250	1,2	<a href="#">22120.0677</a>
16	8	17	M16	1	250	1,4	<a href="#">22120.0678</a>
16	10	17	M16	1	250	2,0	<a href="#">22120.0679</a>
16	12	17	M16	1	250	2,1	<a href="#">22120.0680</a>
16	2	19	M16	3/4	250	1,3	<a href="#">22120.0682</a>
16	4	19	M16	3/4	250	2,8	<a href="#">22120.0684</a>
16	6	19	M16	3/4	250	3,8	<a href="#">22120.0686</a>
16	8	19	M16	3/4	250	4,8	<a href="#">22120.0688</a>
16	10	19	M16	3	250	6,1	<a href="#">22120.0690</a>
16	12	19	M16	3	250	7,3	<a href="#">22120.0692</a>
20	6	22	M20	1/3	250	3,0	<a href="#">22120.0693</a>
20	8	22	M20	1/3	250	4,0	<a href="#">22120.0694</a>
20	10	22	M20	1/3	250	4,9	<a href="#">22120.0695</a>
20	12	22	M20	1/3	250	5,9	<a href="#">22120.0696</a>
20	14	22	M20	1/3	250	6,9	<a href="#">22120.0697</a>
20	16	22	M20	1/3	250	9,3	<a href="#">22120.0698</a>
20	18	22	M20	1/3	250	9,0	<a href="#">22120.0699</a>

应用范例

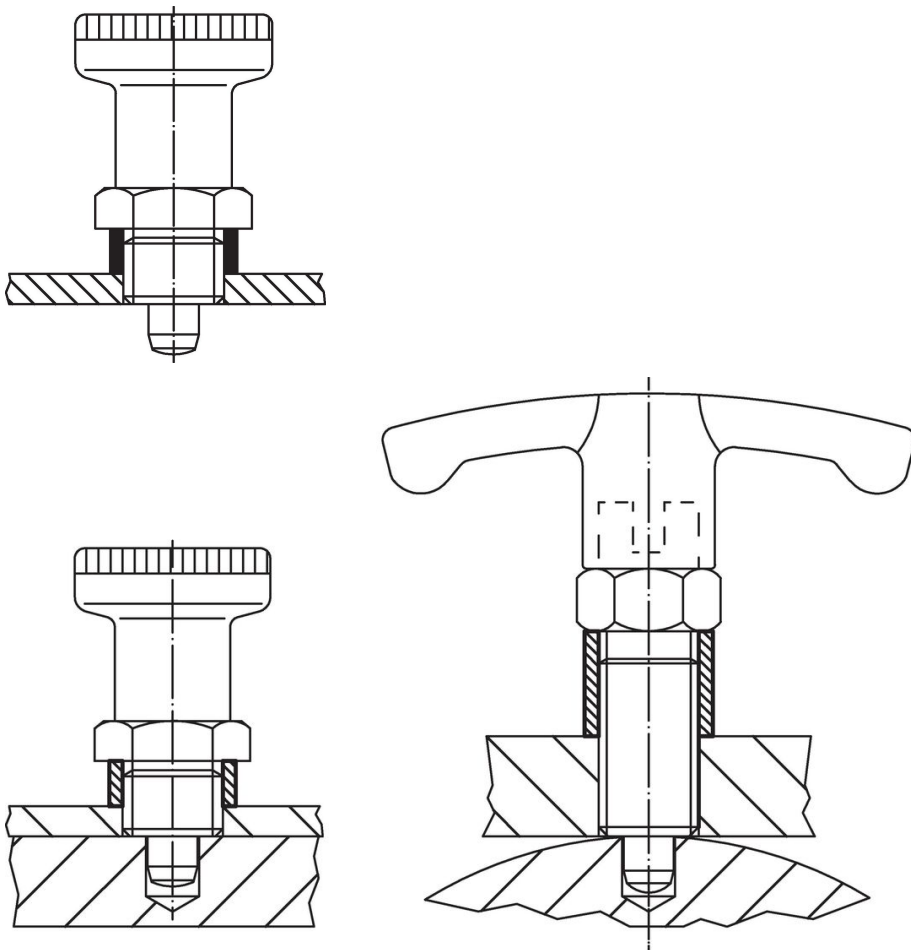

## 遵守

### 符合 RoHS

符合指令 2011/65/EU 和指令 2015/863

### 不含 SVHC 物质

不含超过 0.1% w/w 的 SVHC 物质 - 截至 2024 年 6 月 27 日的 SVHC 清单.

### 不含 65 号提案物质

不包括 65 号提案物质

<https://www.P65Warnings.ca.gov/>

### 不含冲突矿物

„本产品不含来自刚果民主共和国或邻近国家的任何被指定为“冲突矿物”的物质，例如钽、锡、金或钨。