

分割定位柱 · with hexagon collar, stainless steel A4 EH 22120.



产品描述

分割定位目的。
The stainless steel A4 version ensures maximum corrosion resistance.

材质

- 本体**
- Stainless steel 1.4401
- 固定梢子**
- Stainless steel 1.4401 nickel-plated
- 手把**
- 热塑性 PA 6, 黑灰色, 无光泽
 - Stainless steel 1.4401
- 固定螺帽**
- Stainless steel 1.4401

更多信息

注意事项

不可移动的旋钮。
螺帽必须个别购买。

图面

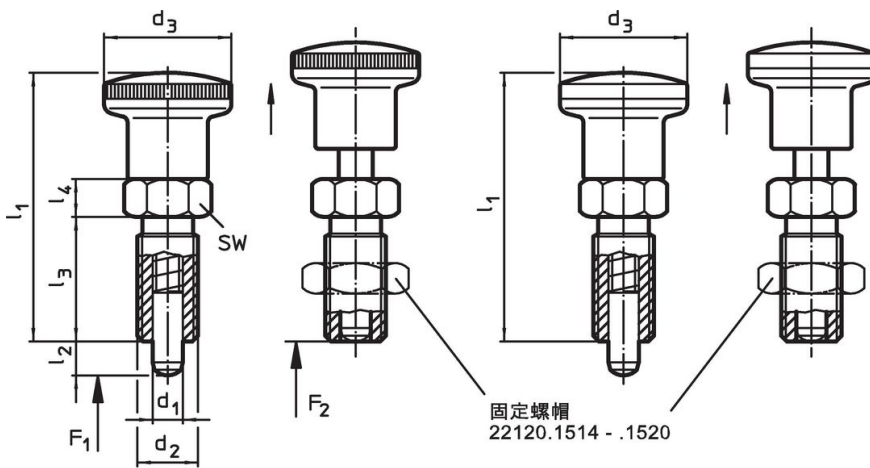



图片 1

图片 2

订单信息



尺寸			尺寸				弹簧荷重 ¹⁾		温度		重量	品号
d ₁	d ₂	l ₂ min	d ₃	l ₁	l ₃	l ₄	F ₁ ~	F ₂ ~	min	max.	[g]	
[mm]			[mm]				[N]		[°C]		[g]	
with knob of thermoplastic – 相片 1												
4	M 8 x 1	4	16	35,0	16	5	3,5	11	-30	80	10	22120.1044
4	M 8 x 1	6	16	35,0	16	5	3,0	11	-30	80	11	22120.1064
5	M10 x 1	5	19	40,0	18	6	3,0	12	-30	80	18	22120.1045
5	M10 x 1	8	19	40,0	18	6	3,0	14	-30	80	18	22120.1065
6	M12 x 1,5	6	23	48,0	22	6	4,5	16	-30	80	30	22120.1046
6	M12 x 1,5	9	23	48,0	22	6	4,0	20	-30	80	30	22120.1066
8	M16 x 1,5	8	28	58,0	26	8	6,0	23	-30	80	66	22120.1068
8	M16 x 1,5	12	28	58,0	26	8	7,0	26	-30	80	63	22120.1048
10	M16 x 1,5	12	28	58,0	26	8	7,5	32	-30	80	64	22120.1080
12	M20 x 1,5	15	33	71,5	33	10	9,0	32	-30	80	129	22120.1082
with knob from stainless steel – 相片 2												
4	M 8 x 1	8	16	35,0	16	5	3,5	11	-	100	20	22120.1054
4	M 8 x 1	6	16	35,0	16	5	3,0	11	-	100	20	22120.1074
5	M10 x 1	5	18	40,0	18	6	3,0	12	-	100	32	22120.1055
5	M10 x 1	8	18	40,0	18	6	3,0	14	-	100	32	22120.1075

¹⁾ 统计平均值

d ₁ -0,02 -0,05	d ₂	l ₂ min	尺寸				弹簧荷重 ¹⁾		 min max.		 [g]	品号
			d ₃	l ₁	l ₃	l ₄	F ₁ ~ [N]	F ₂ ~ [N]	[°C]			
6	M12 x 1,5	6	22	48,0	22	6	4,5	16	-	100	63	22120.1056
6	M12 x 1,5	9	22	48,0	22	6	4,0	20	-	100	56	22120.1076
8	M16 x 1,5	8	27	58,0	26	8	6,0	20	-	100	107	22120.1078
8	M16 x 1,5	12	27	58,0	26	8	7,0	26	-	100	109	22120.1058
10	M16 x 1,5	12	27	58,0	26	8	7,5	32	-	100	111	22120.1090
12	M20 x 1,5	15	32	71,5	33	10	9,0	32	-	100	203	22120.1092

¹⁾ 统计平均值

配件

	尺寸	扳手尺寸	 [g]	品号
	d ₂ [mm]	[mm]	[g]	
Lock nuts ISO 8675 (DIN 439), Stainless steel 1.4401				
	M 8 x 1	13	2,8	22120.1514
	M10 x 1	16	5,4	22120.1515
	M12 x 1,5	18	7,6	22120.1516
	M16 x 1,5	24	18,0	22120.1518
	M20 x 1,5	30	33,0	22120.1520

遵守

For detailed compliance information please select the desired article number.