

## 分割螺栓 EH 22120.



### 产品描述

索引螺栓用于索引  
塑料把手有较佳的握紧力。

### 材质

#### 本体

- 切削钢， 染黑
- 不锈钢 1.4305

#### 固定梢子

- 钢， 硬化
- 不锈钢 1.4305， 镀镍

#### 扣住

- 切削钢， 染黑
- 干燥的粉末金属 1.4404

#### 塑料盖

- 热塑性的， 黑色， 无光泽的

### 操作

藉由旋转分割螺栓 180°， 销子将会缩回并被固定在凹槽处 (此时销子不会弹出)。

### 更多信息

### 注意事项

螺帽必须个别购买。

### 更多产品

- 支持座， 用于分割螺栓和分割定位柱， 压铸
- 定位衬套， 适用于分割螺栓和分割定位柱
- 支持座， 适用于分割螺栓和分割定位柱

### 图面

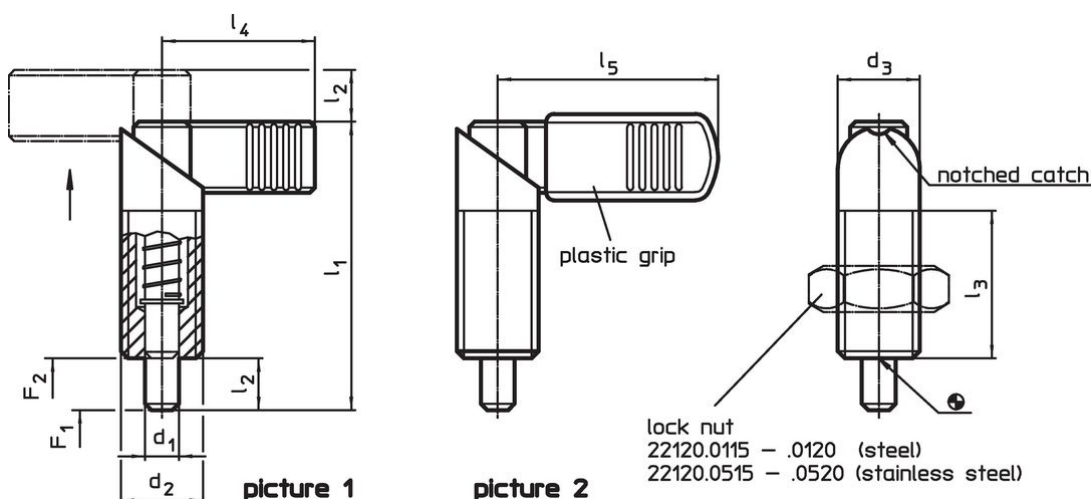

### 订单信息

尺寸		弹簧荷重 <sup>1)</sup>		温度		重量 [g]	品号						
d <sub>1</sub>	d <sub>2</sub>	F <sub>1</sub>	F <sub>2</sub>	min	max.								
-0,02 -0,04		~	~										
[mm]		[N]		[°C]		[g]							
把手无塑胶披复 – 相片 1, 易切削钢													
4	M10 x 1	10	37,5	6	19	21	-	7,0	20,0	-	250	17	22120.0302
5	M10 x 1	10	37,5	6	19	21	-	7,0	20,0	-	250	18	22120.0304
6	M10 x 1	10	37,5	6	19	21	-	7,0	20,0	-	250	18	22120.0306
5	M12 x 1,5	12	47,0	8	26	26	-	8,5	19,5	-	250	29	22120.0313
6	M12 x 1,5	12	47,0	8	26	26	-	8,5	19,5	-	250	29	22120.0314
6	M16 x 1,5	16	56,0	10	30	32	-	11,5	30,5	-	250	75	22120.0316
8	M12 x 1,5	12	47,0	8	26	26	-	8,5	19,5	-	250	30	22120.0315
8	M16 x 1,5	16	56,0	10	30	32	-	11,5	30,5	-	250	61	22120.0317
8	M20 x 1,5	20	69,0	12	36	37	-	21,0	57,5	-	250	121	22120.0318
10	M16 x 1,5	16	56,0	10	30	32	-	11,5	30,5	-	250	64	22120.0319
10	M20 x 1,5	20	69,0	12	36	37	-	21,0	57,5	-	250	128	22120.0320
12	M20 x 1,5	20	69,0	12	36	37	-	21,0	57,5	-	250	127	22120.0322

<sup>1)</sup> 统计平均值

d <sub>1</sub> -0,02 -0,04	d <sub>2</sub>	d <sub>3</sub>	尺寸					弹簧荷重 <sup>1)</sup>		温度		重量 [g]	品号
			l <sub>1</sub>	l <sub>2</sub>	l <sub>3</sub>	l <sub>4</sub>	l <sub>5</sub>	F <sub>1</sub> ~	F <sub>2</sub> ~	min	max.		
			[mm]					[N]		[°C]			
<b>把手无塑胶披复 – 相片 1, 不锈钢</b>													
4	M10 x 1	10	37,5	6	19	21	–	7,0	20,0	–	250	17	22120.0308
5	M10 x 1	10	37,5	6	19	21	–	7,0	20,0	–	250	18	22120.0310
6	M10 x 1	10	37,5	6	19	21	–	7,0	20,0	–	250	18	22120.0312
5	M12 x 1,5	12	47,0	8	26	26	–	8,5	19,5	–	250	29	22120.0323
6	M12 x 1,5	12	47,0	8	26	26	–	8,5	19,5	–	250	29	22120.0324
6	M16 x 1,5	16	56,0	10	30	32	–	11,5	30,5	–	250	75	22120.0326
8	M12 x 1,5	12	47,0	8	26	26	–	8,5	19,5	–	250	30	22120.0325
8	M16 x 1,5	16	56,0	10	30	32	–	11,5	30,5	–	250	61	22120.0327
8	M20 x 1,5	20	69,0	12	36	37	–	21,0	57,5	–	250	121	22120.0328
10	M16 x 1,5	16	56,0	10	30	32	–	11,5	30,5	–	250	64	22120.0329
10	M20 x 1,5	20	69,0	12	36	37	–	21,0	57,5	–	250	128	22120.0330
12	M20 x 1,5	20	69,0	12	36	37	–	21,0	57,5	–	250	127	22120.0332
<b>把手有塑胶披复 – 相片 2, 易切削钢</b>													
5	M12 x 1,5	12	47,0	8	26	–	32	8,5	19,5	-30	80	30	22120.0353
6	M12 x 1,5	12	47,0	8	26	–	32	8,5	19,5	-30	80	30	22120.0354
6	M16 x 1,5	16	56,0	10	30	–	42	11,5	30,5	-30	80	61	22120.0356
8	M12 x 1,5	12	47,0	8	26	–	32	8,5	19,5	-30	80	32	22120.0355
8	M16 x 1,5	16	56,0	10	30	–	42	11,5	30,5	-30	80	63	22120.0357
8	M20 x 1,5	20	69,0	12	36	–	52	21,0	57,5	-30	80	124	22120.0358
10	M16 x 1,5	16	56,0	10	30	–	42	11,5	30,5	-30	80	66	22120.0359
10	M20 x 1,5	20	69,0	12	36	–	52	21,0	57,5	-30	80	128	22120.0360
12	M20 x 1,5	20	69,0	12	36	–	52	21,0	57,5	-30	80	131	22120.0362
<b>把手有塑胶披复 – 相片 2, 不锈钢</b>													
5	M12 x 1,5	12	47,0	8	26	–	32	8,5	19,5	-30	80	30	22120.0363
6	M12 x 1,5	12	47,0	8	26	–	32	8,5	19,5	-30	80	30	22120.0364
6	M16 x 1,5	16	56,0	10	30	–	42	11,5	30,5	-30	80	61	22120.0366
8	M12 x 1,5	12	47,0	8	26	–	32	8,5	19,5	-30	80	32	22120.0365
8	M16 x 1,5	16	56,0	10	30	–	42	11,5	30,5	-30	80	63	22120.0367
8	M20 x 1,5	20	69,0	12	36	–	52	21,0	57,5	-30	80	124	22120.0368
10	M16 x 1,5	16	56,0	10	30	–	42	11,5	30,5	-30	80	66	22120.0369
10	M20 x 1,5	20	69,0	12	36	–	52	21,0	57,5	-30	80	128	22120.0370
12	M20 x 1,5	20	69,0	12	36	–	52	21,0	57,5	-30	80	131	22120.0372

<sup>1)</sup> 统计平均值

## 配件

	尺寸 d <sub>2</sub> [mm]	扳手尺寸 [mm]	重量 [g]	品号
<b>Lock nuts ISO 8675 (DIN 439), 钢</b>				
	M10 x 1	16	5,2	22120.0115
	M12 x 1,5	18	7,5	22120.0116
	M16 x 1,5	24	15,0	22120.0118
	M20 x 1,5	30	32,0	22120.0120
<b>Lock nuts ISO 8675 (DIN 439), 不锈钢</b>				
	M10 x 1	16	5,2	22120.0515
	M12 x 1,5	18	7,5	22120.0516
	M16 x 1,5	24	15,0	22120.0518
	M20 x 1,5	30	32,0	22120.0520

## 遵守

For detailed compliance information please select the desired article number.