

## 分割定位柱的迷你分割

EH 22110.



### 产品描述

特别适合锁附薄板。  
效能于最小空间需求。

### 材质

本体

- 钢，镀锌
- 不锈钢 1.4305

固定梢子

- 不锈钢 1.4305

手把

- 塑料(PA6)，黑色，无光泽的
- Thermoplast PA 6, red, dull

### 组装

锁入迷你分割定位柱。提起旋钮，六角将会松开以便组立。

螺丝长度可由分割定位柱衬套调整 (EH 22120.)。

### 操作

当使用自锁型旋钮，拉出旋钮，转30度并由一个缺口夹住。

### 更多信息

### 注意事项

不可移动的旋钮。

### 更多产品

- 距离调整环，适用于分割定位柱

### 图面

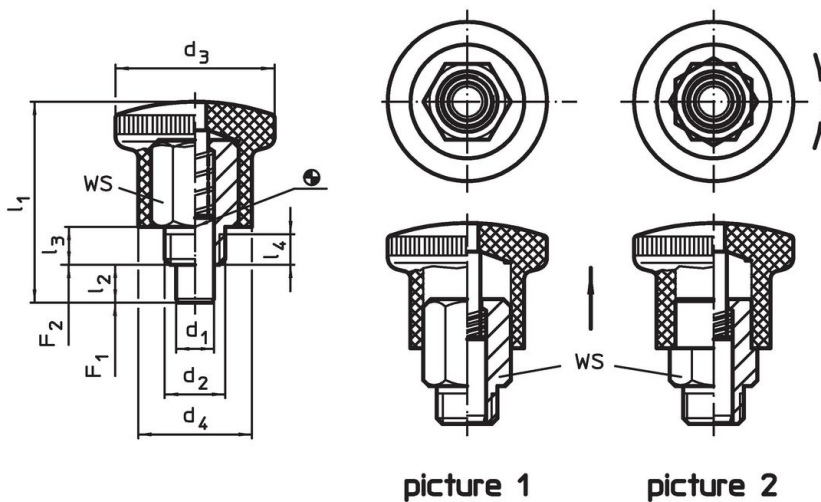

picture 1

picture 2

### 订单信息

d <sub>1</sub>	d <sub>2</sub>	d <sub>3</sub>	尺寸					WS	弹簧荷重 <sup>1)</sup>		温度		重量	品号	
			d <sub>4</sub>	l <sub>1</sub>	l <sub>2</sub> min	l <sub>3</sub>	l <sub>4</sub> min		F <sub>1</sub> ~	F <sub>2</sub> ~	min	max.			
0 -0,06															
[mm]															
[N]															
[°C]															
[g]															
<b>without locking, knob black – 相片 1, 钢</b>															
4	M 8 x 0,75	21	15	26,5	5	5	3,5	10	4,5	12	-30	80	14	<a href="#">22110.0024</a>	
5	M 8 x 0,75	21	15	26,5	5	5	3,5	10	4,5	12	-30	80	14	<a href="#">22110.0026</a>	
6	M10 x 1	25	18	34,0	7	7	4,5	12	5,0	18	-30	80	25	<a href="#">22110.0028</a>	
7	M10 x 1	25	18	34,0	7	7	4,5	12	5,0	18	-30	80	26	<a href="#">22110.0030</a>	
<b>without locking, knob red – 相片 1, 钢</b>															
4	M 8 x 0,75	21	15	26,5	5	5	3,5	10	4,5	12	-30	80	14	<a href="#">22110.2024</a>	
5	M 8 x 0,75	21	15	26,5	5	5	3,5	10	4,5	12	-30	80	14	<a href="#">22110.2026</a>	
6	M10 x 1	25	18	34,0	7	7	4,5	12	5,0	18	-30	80	25	<a href="#">22110.2028</a>	
7	M10 x 1	25	18	34,0	7	7	4,5	12	5,0	18	-30	80	25	<a href="#">22110.2030</a>	

<sup>1)</sup> 统计平均值

d <sub>1</sub> 0 -0,06	d <sub>2</sub>	d <sub>3</sub>	尺寸					WS [mm]	弹簧荷重 <sup>1)</sup>		温度		重量 [g]	品号	
			d <sub>4</sub>	l <sub>1</sub>	l <sub>2</sub> min	l <sub>3</sub>	l <sub>4</sub> min		F <sub>1</sub> ~ [N]	F <sub>2</sub> ~ [N]	min [°C]	max.			
<b>with locking, knob black – 相片 2, 钢</b>															
4	M 8 x 0,75	21	15	26,5	5	5	3,5	10	4,5	12	-30	80	13	<a href="#">22110.0034</a>	
5	M 8 x 0,75	21	15	26,5	5	5	3,5	10	4,5	12	-30	80	14	<a href="#">22110.0036</a>	
6	M10 x 1	25	18	34,0	7	7	4,5	12	5,0	18	-30	80	24	<a href="#">22110.0038</a>	
7	M10 x 1	25	18	34,0	7	7	4,5	12	5,0	18	-30	80	25	<a href="#">22110.0040</a>	
<b>with locking, knob red – 相片 2, 钢</b>															
4	M 8 x 0,75	21	15	26,5	5	5	3,5	10	4,5	12	-30	80	13	<a href="#">22110.2034</a>	
5	M 8 x 0,75	21	15	26,5	5	5	3,5	10	4,5	12	-30	80	14	<a href="#">22110.2036</a>	
6	M10 x 1	25	18	34,0	7	7	4,5	12	5,0	18	-30	80	24	<a href="#">22110.2038</a>	
7	M10 x 1	25	18	34,0	7	7	4,5	12	5,0	18	-30	80	25	<a href="#">22110.2040</a>	
<b>without locking, knob black – 相片 1, 不锈钢</b>															
4	M 8 x 0,75	21	15	26,5	5	5	3,5	10	4,5	12	-30	80	14	<a href="#">22110.0044</a>	
5	M 8 x 0,75	21	15	26,5	5	5	3,5	10	4,5	12	-30	80	14	<a href="#">22110.0046</a>	
6	M10 x 1	25	18	34,0	7	7	4,5	12	5,0	18	-30	80	25	<a href="#">22110.0048</a>	
7	M10 x 1	25	18	34,0	7	7	4,5	12	5,0	18	-30	80	26	<a href="#">22110.0050</a>	
<b>without locking, knob red – 相片 1, 不锈钢</b>															
4	M 8 x 0,75	21	15	26,5	5	5	3,5	10	4,5	12	-30	80	14	<a href="#">22110.2044</a>	
5	M 8 x 0,75	21	15	26,5	5	5	3,5	10	4,5	12	-30	80	14	<a href="#">22110.2046</a>	
6	M10 x 1	25	18	34,0	7	7	4,5	12	5,0	18	-30	80	25	<a href="#">22110.2048</a>	
7	M10 x 1	25	18	34,0	7	7	4,5	12	5,0	18	-30	80	25	<a href="#">22110.2050</a>	
<b>with locking, knob black – 相片 2, 不锈钢</b>															
4	M 8 x 0,75	21	15	26,5	5	5	3,5	10	4,5	12	-30	80	13	<a href="#">22110.0054</a>	
5	M 8 x 0,75	21	15	26,5	5	5	3,5	10	4,5	12	-30	80	14	<a href="#">22110.0056</a>	
6	M10 x 1	25	18	34,0	7	7	4,5	12	5,0	18	-30	80	24	<a href="#">22110.0058</a>	
7	M10 x 1	25	18	34,0	7	7	4,5	12	5,0	18	-30	80	25	<a href="#">22110.0060</a>	
<b>with locking, knob red – 相片 2, 不锈钢</b>															
4	M 8 x 0,75	21	15	26,5	5	5	3,5	10	4,5	12	-30	80	13	<a href="#">22110.2054</a>	
5	M 8 x 0,75	21	15	26,5	5	5	3,5	10	4,5	12	-30	80	14	<a href="#">22110.2056</a>	
6	M10 x 1	25	18	34,0	7	7	4,5	12	5,0	18	-30	80	24	<a href="#">22110.2058</a>	
7	M10 x 1	25	18	34,0	7	7	4,5	12	5,0	18	-30	80	25	<a href="#">22110.2060</a>	

<sup>1)</sup> 统计平均值

应用范例



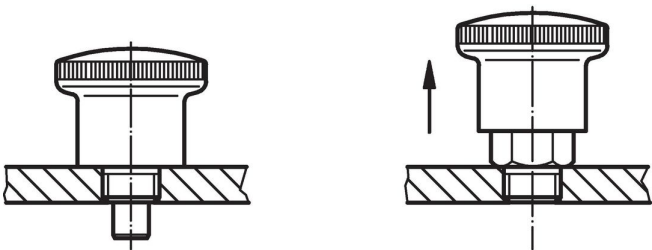
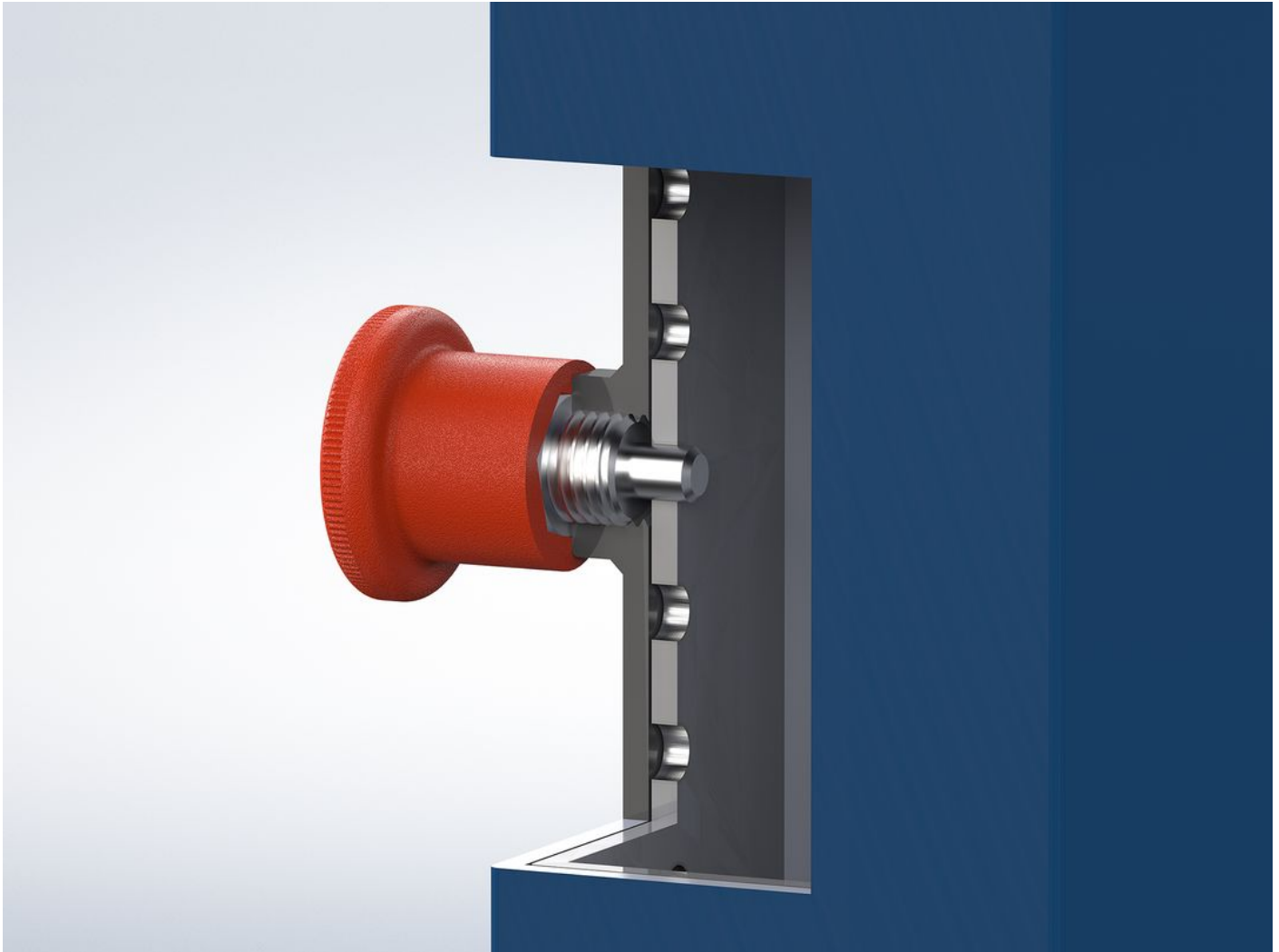

**遵守**

For detailed compliance information please select the desired article number.