

夹持棒 · 长度 200
EH 1585.



产品描述

材质

- 工具钢，硬化

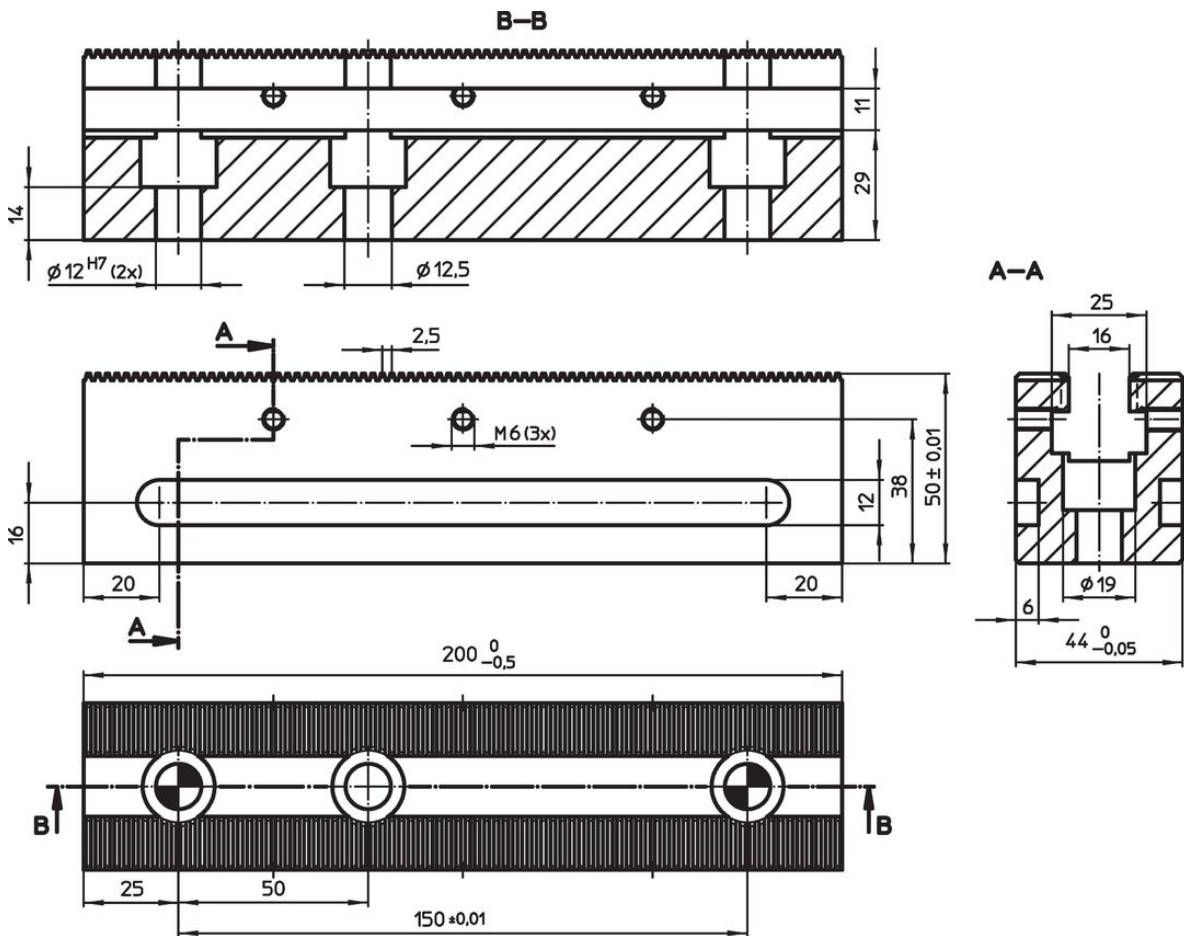

图面



订单信息

[kg]	品号
2	1585.200

配件

	定位螺丝数量 M12 x 45	有头螺丝数量 M12 x 45	 [g]	品号
固定螺丝用于夹持杆				
	2	1	155	1585.201

遵守

For detailed compliance information please select the desired article number.