

绞链 · Zinc die-cast, with indexing positions

25164.0010

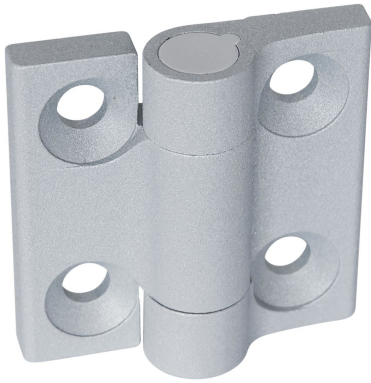

产品描述

Hinges from zinc die-cast with indexing positions hold door and covers in fixed positions. It avoids undesired automatic closing or opening. This is an advantage for example when filling machines and facilities or during maintenance and repairs.

The version with the indexing positions -3° and 117° (picture 2) also ensures that the door or cover presses slightly against the housing frame by the -3° when closed.

These hinges from zinc die-cast are characterised by their simple and timeless design.

材质

本体

- 锌压铸, 表面涂装, 银色, 类似 RAL 9006, 雾面

轴

- 不锈钢 1.4305

弹簧

- 弹簧钢丝

更多信息

更多产品

- 分隔板, 用于绞链
- 螺纹板, 用于绞链

图面

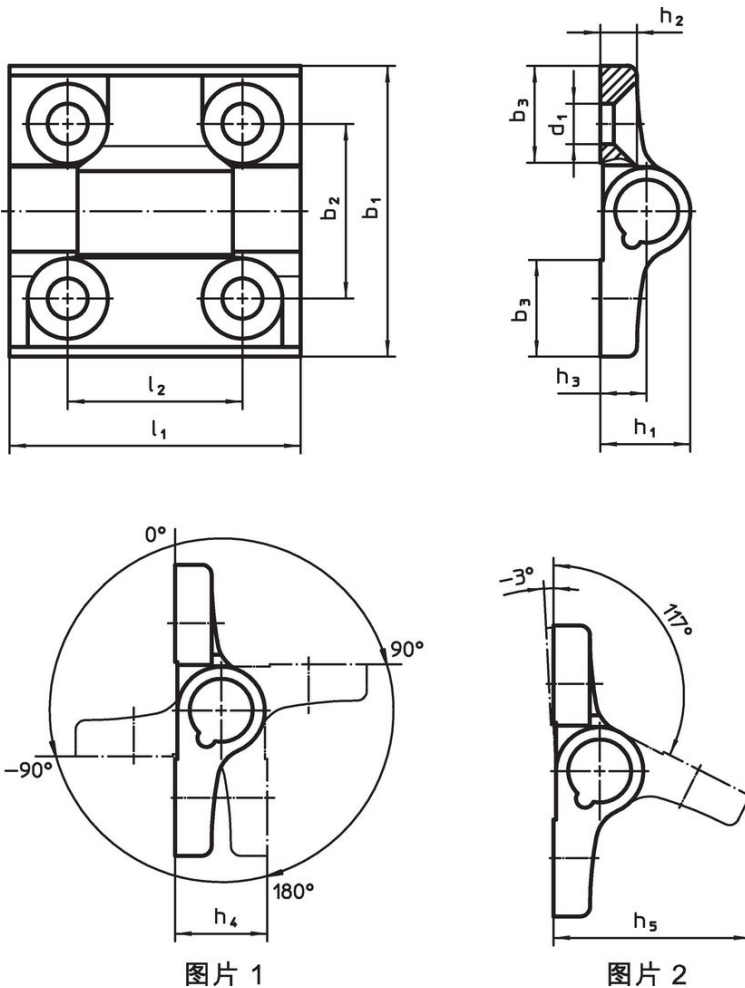

图片 1

图片 2

订单信息

尺寸											max. [°C]	[g]	品号		
b ₁	l ₁	b ₂	b ₃	d ₁	h ₁	h ₂	h ₃	h ₄	h ₅	l ₂					
indexing positions -3° and 117° – 相片 2, 锌压铸, 银															
60	60	36	20	8,3	18,5	7,5	9,5	19	40,5	36	80	152	25164.0010		

遵守

符合 RoHS

符合指令 2011/65/EU 和指令 2015/863

不含 SVHC 物质

不含超过 0.1% w/w 的 SVHC 物质 - 截至 2024 年 6 月 27 日的 SVHC 清单.

不含 65 号提案物质

不包括 65 号提案物质

<https://www.P65Warnings.ca.gov/>

不含冲突矿物

„本产品不含来自刚果民主共和国或邻近国家的任何被指定为“冲突矿物”的物质，例如钽、锡、金或钨。