

中心夹持心轴 · 圆柱形止位块

23340.0512



产品描述

The centering clamping mandrels, cylindrical are ideal for use in fixture construction. They enable workpieces to be clamped with a hole on their inside diameter and therefore without interfering clamping edges. The centering clamping mandrels can be mounted on grid and fixture plates, for example, by pressing them into bores or screwing them into threads.

They enable exact positioning, offer precise repeat accuracy and achieve high holding forces when clamping parts with holes. The centering clamping mandrels offer the possibility of fixing complex workpieces without external clamping elements to enable these components to be machined on 5 sides.

The centering clamping mandrels, cylindrical have the following characteristics:

- Clamping stroke max. 0.7 mm
- Two versions - for press-in or screw-in
- Made of stainless steel or free-cutting steel
- Clamping body can be machined very easily (for adaptation to bore diameter)

材质

本体

- 易切削钢

夹持螺丝

- 钢

组装

The centering clamping mandrel can be adjusted to the respective diameter by turning or milling.

Picture 1 - Mounting in bore hole or socket.

Thread for clamping screw required.

Picture 2 – Mounting in thread.

Clamping screw for the mounting.

Remove from body.

Screw-in centering clamping elements and tighten using the wrench size (WS₂).

操作

It is operated using the conical clamping screw (WS1). This expands the body by up to 0.7 mm.

图面

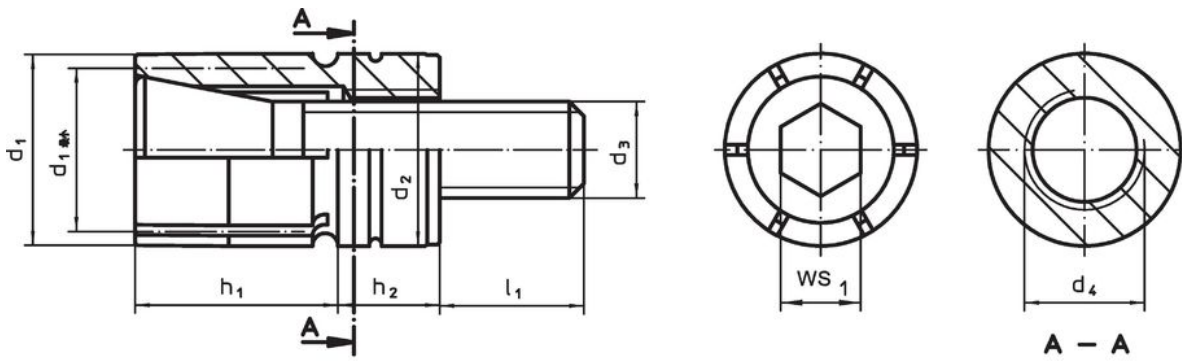

图片 1

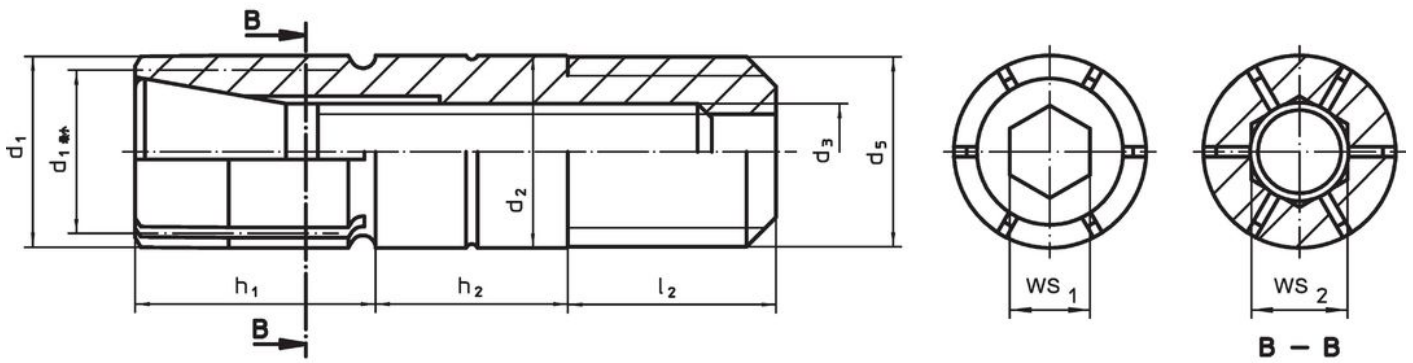

图片 2

订单信息

d_1	d_1 min	d_2 -0,025	d_3	尺寸 d_4 h_1 h_2 l_1 [mm]				WS WS ₁ [mm]	部 门数	夹持力量 max. [kN]	起动 扭力 max. [Nm]	定位孔 [mm]	 [g]	品号
12	10,5	12	M6	M8	12,7	6,35	11,1	5	6	8,5	17	12	17	23340.0512

press-fit – 相片 1, 易切削钢

应用范例

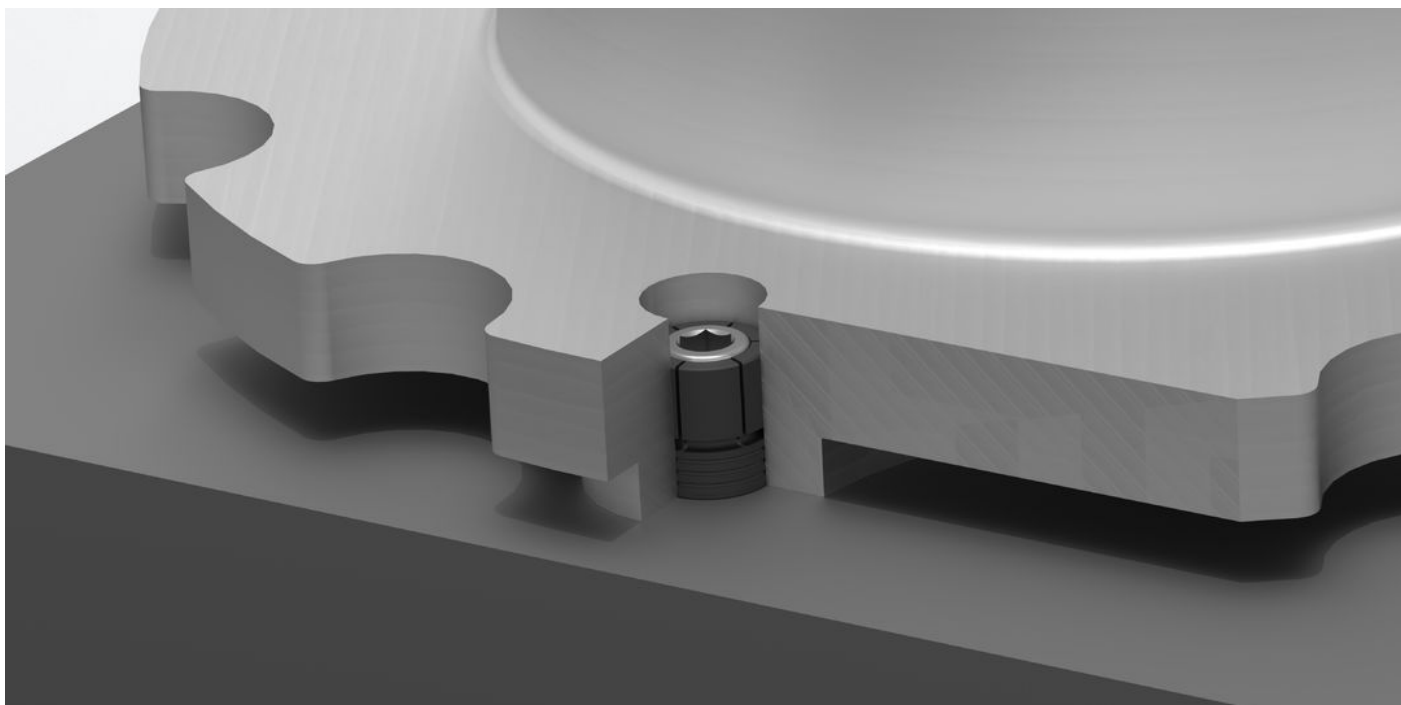

遵守

符合 RoHS

符合指令 2011/65/EU 和指令 2015/863

不含 SVHC 物质

不含超过 0.1% w/w 的 SVHC 物质 - 截至 2024 年 1 月 23 日的 SVHC 清单.

不含 65 号提案物质

不包括 65 号提案物质

<https://www.P65Warnings.ca.gov/>

不含冲突矿物

„本产品不含来自刚果民主共和国或邻近国家的任何被指定为“冲突矿物”的物质，例如钽、锡、金或钨。