

偏心夹持夹具 · with slot tenon

23270.0418



产品描述

The eccentric clamping clamps can be used for quick and easy workpiece clamping directly on the machine table or a base plate with T-slots.

These eccentric clamping clamps with slot tenon are locked in a T-slot, for example on the machine table, with a thrust screw. Clamping takes place via the clamping screw with eccentric head. The brass basic element ensures gentle and secure clamping.

The eccentric clamping clamps with slot tenon have the following characteristics:

- Brass base element for material-friendly clamping
- Quick clamping thanks to clamping screw with eccentric head
- High clamping force is achieved
- Low design enables the machining of flat workpieces
- The compact dimensions enable space-saving multiple clamping

材质

偏心螺丝

- 钢

螺纹销

- 钢, 染黑

本体

- 黄铜

Slot tenon

- 钢, 硬化, 染黑

图面

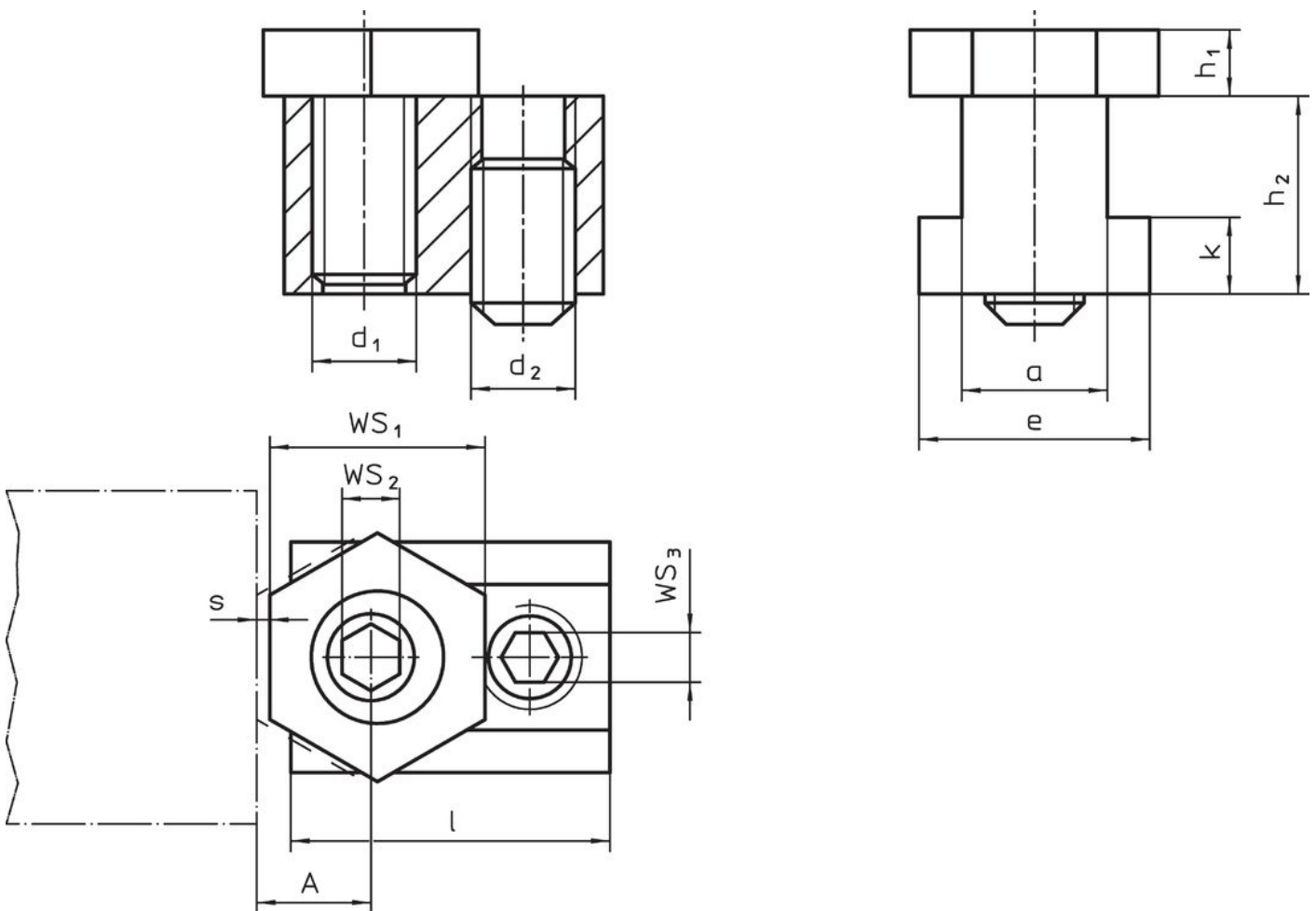

订单信息

T槽 尺寸 [mm]	d <sub>1</sub>	a	e	尺寸					A	WS <sub>1</sub>	WS		夹持力量 max. [kN]	起动 扭力 WS <sub>2</sub> max. [Nm]	起动 扭力 WS <sub>3</sub> max. [Nm]	📦	品号
				h <sub>1</sub>	h <sub>2</sub>	k	s	l			WS <sub>2</sub>	WS <sub>3</sub>					
18	M12	17,7	28,5	9,5	28,5	10,5	2,5	34,7	12,7	25,4	8	6	9	75	55	190	23270.0418

应用范例

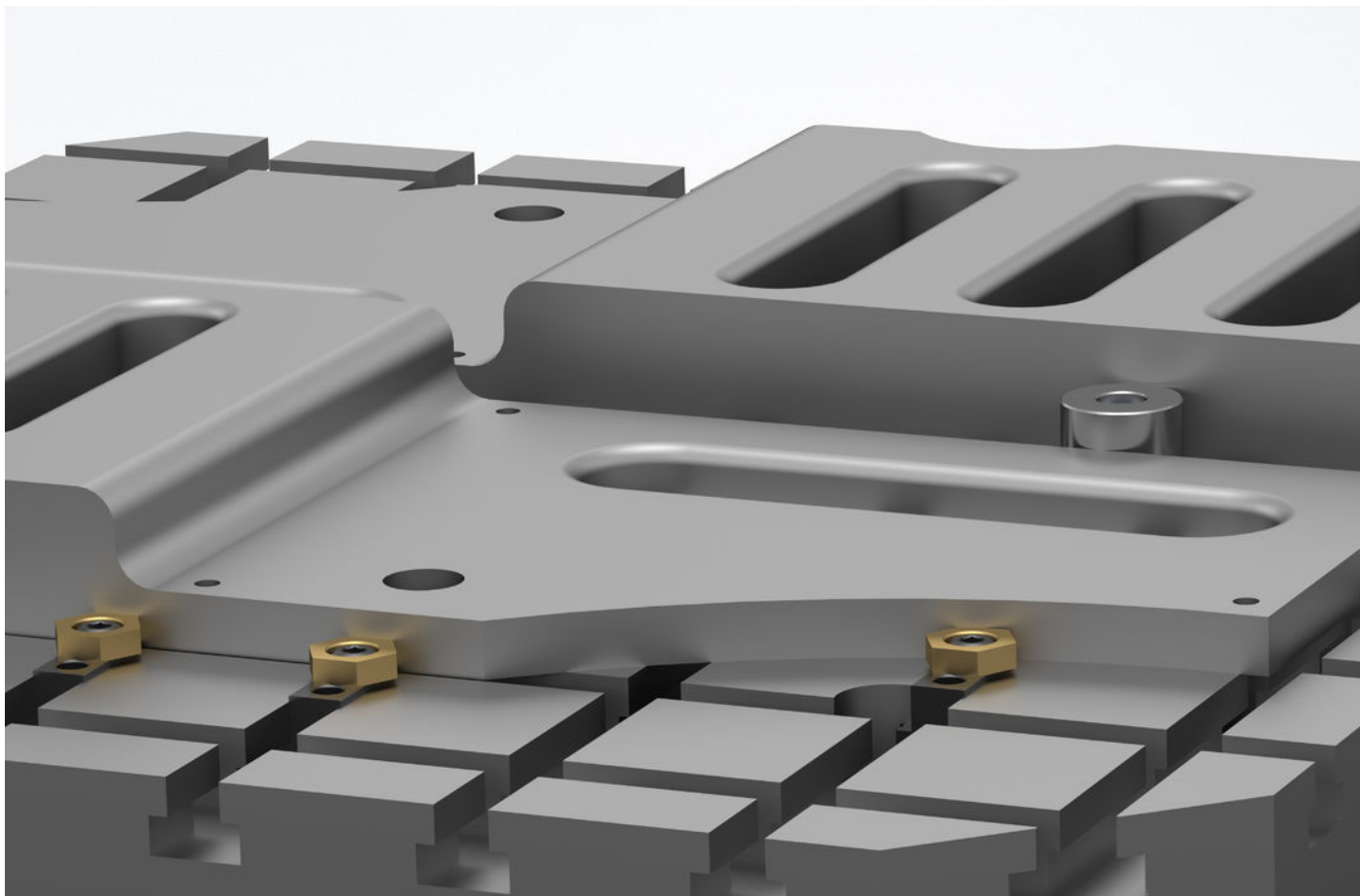

遵守

符合指令 2011/65/EU 和指令 2015/863

不含超过 0.1% w/w 的 SVHC 物质 - 截至 2024 年 6 月 27 日的 SVHC 清单.

不包括 65 号提案物质

<https://www.P65Warnings.ca.gov/>