

螺纹顶上销 · 自锁，带把手

22354.5008

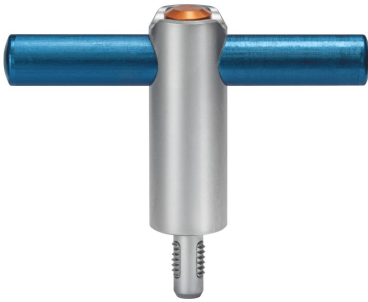

产品描述

T型手柄的把手可以经由手来移动或输送工件，例如，零件成品组件，工件夹持系统，扬声器和其他容器。

Heavy-duty lifting element with handle for quick and easy use. For lifting loads, the threaded lifting pin is inserted into a threaded hole. In contrast to a ringbolt, time-consuming screwing in and out is therefore unnecessary.

抗腐蚀和摩擦，因此适用于户外。非常扎实，高负载力的沉淀硬化销。

材质

销子零件

- 不锈钢 1.4542、沉淀硬化

把手

- 铝，蓝电镀

按钮

- 铝，橘色，阳极

螺纹元件

- 不锈钢 1.4542、沉淀硬化

弹簧

- 不锈钢

组装

Threaded lifting pins can be mounted into a thread that is true to gauge.

Mounting:

1. Press in the button and hold it down.
2. Insert the threaded lifting pin.
3. Release the button (The button must be back in its original position. A clearly visible green marking on the press button indicates the correct position.).
4. Tighten the threaded lifting pin by hand, until it bears completely on the bearing surface.
5. It must be ensured that the threaded segments are engaged in the mounting thread.

Dismantling:

1. Unscrew the threaded lifting pin approx. a quarter of a turn anticlockwise.
2. Press in the button and hold it down.
3. Remove the threaded lifting pin.
4. Release the button.

操作

Each threaded lifting pin is supplied with operating instructions. This document is also available for download as a PDF.

图面

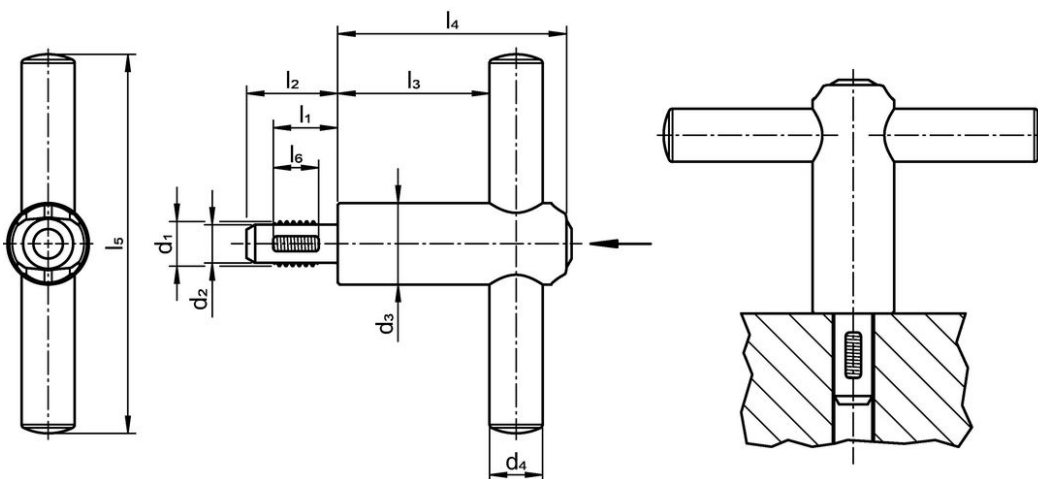

订单信息

尺寸										荷重能力	定位螺牙	🌡️	📦	品号
d ₁	l ₁	d ₂ -0,07	d ₃	d ₄	l ₂	l ₃	l ₄	l ₅	l ₆	F ₁		max.		
[mm]										[N]	[mm]	[°C]	[g]	
M8	12	6,62	21,5	14	17,3	40	60,3	100	8	500	M8	250	194	22354.5008

应用范例

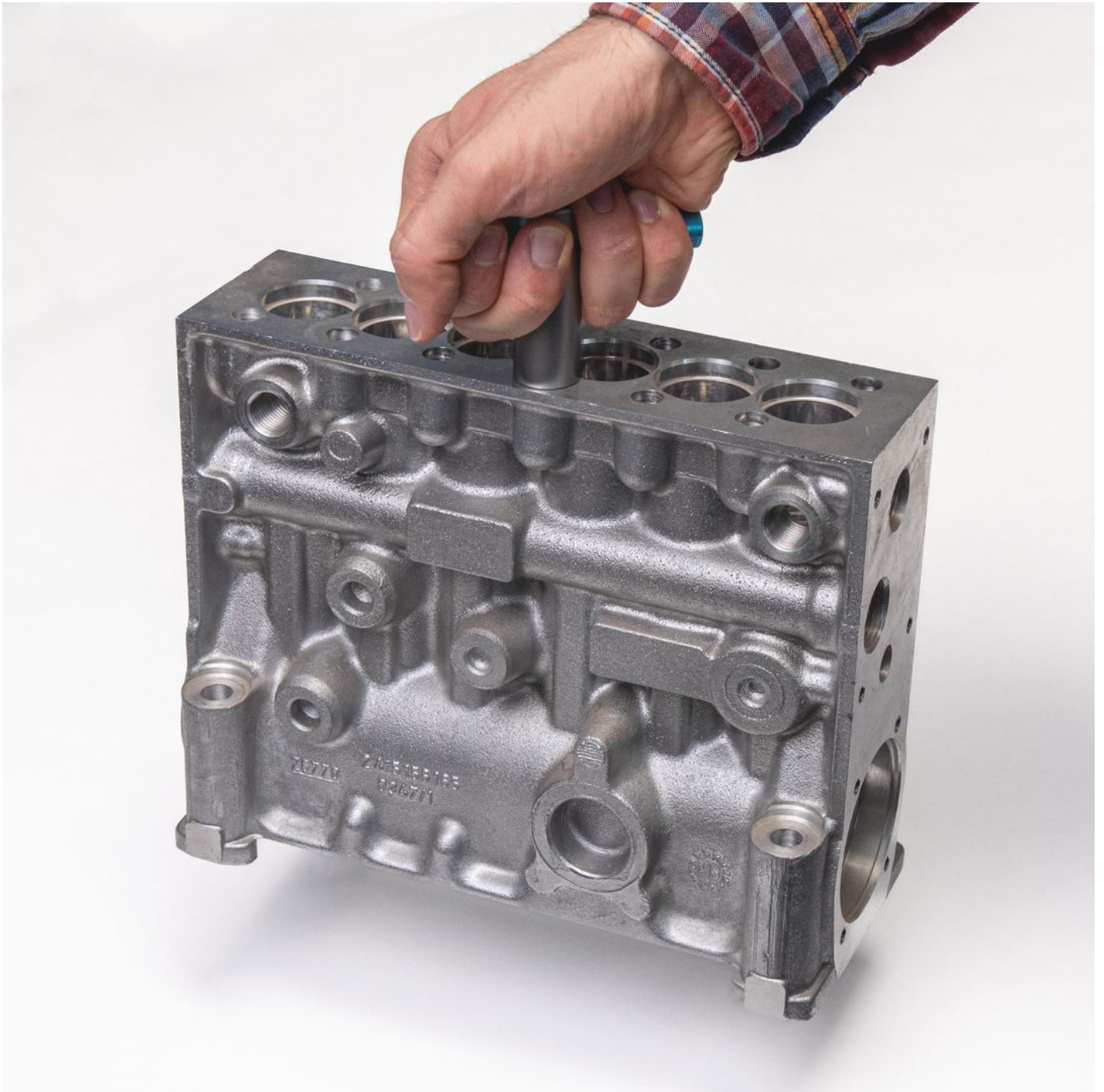

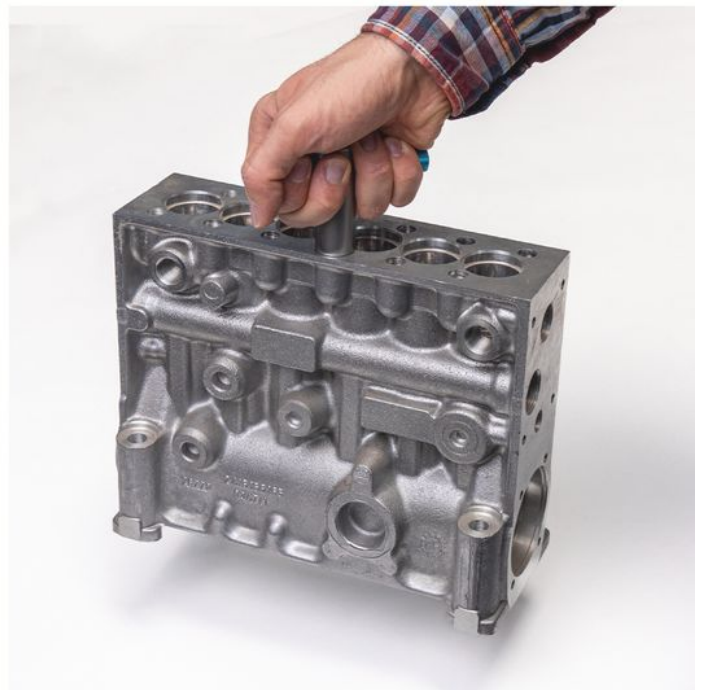



遵守

不符合 RoHS

不符合指令 2011/65/EU 和指令 2015/863

含有 >0.1% w/w 的 SVHC 物质

含铅 - SVHC [REACH] 清单截至 2024 年 6 月 27 日

包含 65 号提案的物质



铅暴露会导致癌症和生殖伤害

<https://www.P65Warnings.ca.gov/>

不含冲突矿物

„本产品不含来自刚果民主共和国或邻近国家的任何被指定为“冲突矿物”的物质，例如钽、锡、金或钨。