

分割定位柱 · 带有感应器

22123.0108



产品描述

分割定位目的。

The index plunger with sensor makes it possible to monitor the indexing position of the indexing plunger. When it engages, the sensor already switches after 2/3 of the indexing distance l_2 . In addition to the electronic signal, the switching status is indicated directly on the sensor via an LED.

材质

本体

- 不锈钢 1.4305

固定梢子

- 不锈钢 1.4305, 镀镍

手把

- 塑料(PA6), 黑色, 无光泽的

缆线

- 热塑性 PUR, 黑色

磁铁

- 永久磁鐵

感测器

- 塑料(PA6), 黑色, 无光泽的

固定螺帽

- Stainless steel A2 (ISO 8675)

组装

The enclosed separate sensor and sensor clip can be mounted with the enclosed Allen key. The derivation direction of the sensor cable can be determined individually.

1. Push the sensor into the side of the sensor clip.
2. Tighten the internal hexagon screw of the sensor with light hand force (max. 0.1 Nm).
3. Clip the sensor clip into the annular groove of the index plunger in any position.
4. By turning the sensor clip, the sensor cable's derivation direction can be adjusted.

Note:

To avoid interferences, no magnetic fields should act on the index plunger.

操作

当使用锁定分割定位柱时, 拉出旋钮, 转90度并由一个槽口固定 (此时锁销不可突出)。

更多信息

注意事项

不可移动的旋钮。

更多产品

- 轮询元件, 带有感应器

图面

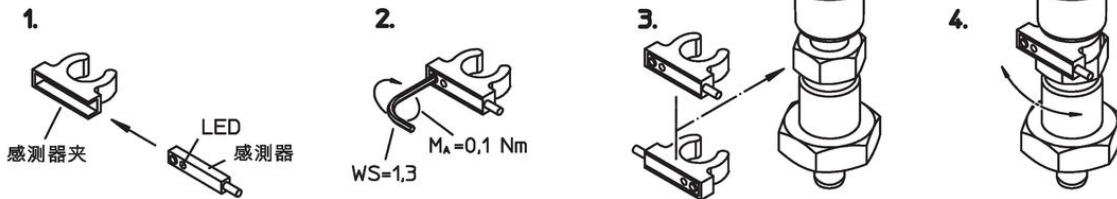
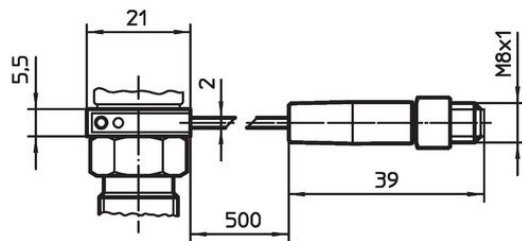
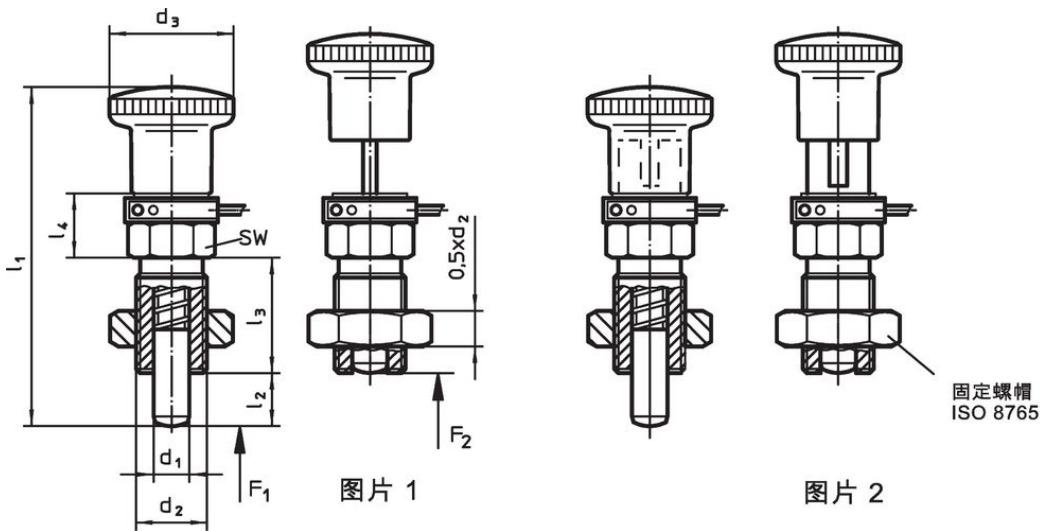

订单信息

尺寸		WS	弹簧荷重 ¹⁾		温度		重量 [g]	品号					
d ₁	d ₂		F ₁	F ₂	min	max.							
-0,02 -0,05		[mm]	[N]	[°C]	[g]								
	l ₂ min												
	d ₃												
	l ₁												
	l ₃												
	l ₄												
有手把 有锁固 - 相片 2													
8	M16 x 1,5	12	28	64,5	26	14,5	17	8,5	28	-25	75	112	22123.0108

¹⁾ 统计平均值

应用范例



遵守

符合 RoHS

符合指令 2011/65/EU 和指令 2015/863

不含 SVHC 物质

不含超过 0.1% w/w 的 SVHC 物质 - 截至 2024 年 1 月 23 日的 SVHC 清单.

不含 65 号提案物质

不包括 65 号提案物质

<https://www.P65Warnings.ca.gov/>

不含冲突矿物