

## 分割螺栓 · 无螺纹，有焊接

22120.1720



### 产品描述

#### 索引螺栓用于索引

This index bolt made of steel or stainless steel is available in two versions.

- riveted
- screwed

### 材质

#### 固定销子

- 钢，镀锌，钝化

### 组装

We recommend the screwed version for welded joints. The final assembly of the index bolt can then take place after the body has been welded:

1. Weld on body (3)
2. Place the spring (2) on the locking pin (1) and insert it into the body (3)
3. Tighten the bolt (4) with the screw (5) on the locking pin (1)

The riveted version is also suitable for fastening by welding. However, care must be taken to ensure that the effect of heat is limited (e.g. by fixing with weld spots) and that there are no structural changes to the spring and bolt.

### 操作

藉由旋转分割螺栓 180°，销子将会缩回并被固定在凹槽处 (此时销子不会弹出)。

### 图面

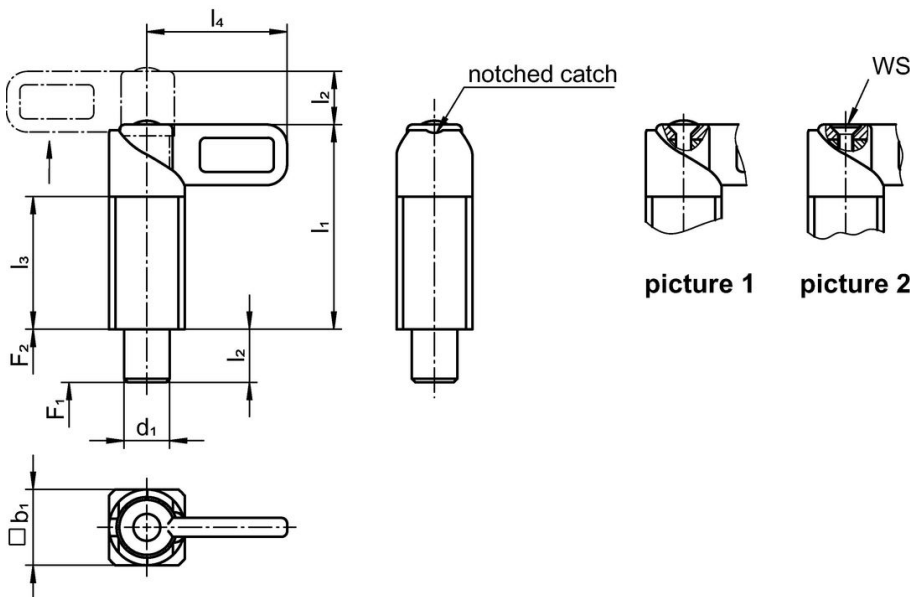

### 订单信息

尺寸						WS	弹簧荷重 <sup>1)</sup>		🌡️	🔩	品号
d <sub>1</sub>	b <sub>1</sub>	l <sub>1</sub>	l <sub>2</sub>	l <sub>3</sub>	l <sub>4</sub>		F <sub>1</sub>	F <sub>2</sub>	max.		
[mm]						[mm]	[N]		[°C]	[g]	
-0.05		~									
-0.25											
screwable (removable) – 相片 2											
14	20	54	14	35	37	2,5	14	35	250	150	22120.1720

<sup>1)</sup> 统计平均值

## 应用范例



## 遵守

### 符合 RoHS

符合指令 2011/65/EU 和指令 2015/863

### 不含 SVHC 物质

不含超过 0.1% w/w 的 SVHC 物质 - 截至 2024 年 1 月 23 日的 SVHC 清单.

### 不含 65 号提案物质

不包括 65 号提案物质

<https://www.P65Warnings.ca.gov/>

### 不含冲突矿物

„本产品不含来自刚果民主共和国或邻近国家的任何被指定为“冲突矿物”的物质，例如钽、锡、金或钨。